

Vehicle Locating Small GPS/GSM/FM Antenna

MODEL: GFA-650L

Small size and ruggedness, demand of vehicle locating and car navigation GPS antenna that will sustain harsh environment.



- Low noise figure
- Fully weather proof IPX7 .
- Ultra-high Sensitivity
- Compact construction
- Excellent temperature stability

The antenna system **GFA-65L** is the integration of the high performance GPS patch antenna and a low noise amplifier into state-of-the-art low a very low profile/extremely compact/fully waterproof antenna signal enclosure. When connected to a GPS receiver with +2.5~ 5.5V DC antenna powers it provides excellent signal amplification and out-band-rejection for that receiver.

Features:

GPS antenna with double threaded bolts and through holes for cable routing with course & fine treaded pitch locking for wing-nut fastener and lock-nut to prevent vibrations and un-authorized removal.

Specifications:

| PHYSICAL CONDITION | |
|-------------------------|---|
| Constructions: | Polycarbonate radome, detachable cable/connector for easy mount, rubber-O-ring between top radome and screw base for waterproof |
| Dimensions: | 60mm(Dia.) x 45mm(H) |
| Weight: | 65grams (w/o cable & connector). |
| Color: | White or Black (Optional) |
| Mounting: | Bulkhead mount with 0.8 inch threaded wing nut (standard accessory). |
| Cable & Connector | |
| RF cable: | RG174 -5M, |
| Pulling strength: | 6 Kg @ 5sec. molded plastic on connector end for strain relief. |
| Connector available: | SMA ,SMB,Fakra ,BNC,TNC,MMCX,MCX---- |
| Antenna Element | |
| Center Frequency: | 1575.42 MHz +/-1.023 MHz |
| Polarization: | R.H.C.P. (Right Handed Circular Polarization). |
| Absolute Gain @ Zenith: | +5 dBi typical. |
| Gain @ 10° Elevation: | -1 dBi typical. |
| Axial Ratio: | 3 dB max. |
| Output VSWR: | 2.0 |
| Output Impedance: | 50 ohm |

| Low Noise Amplifier | |
|----------------------------|--|
| Center Frequency: | 1575.42 +/- 1.023 MHz |
| Power Gain: | 28 db +/-3db |
| Bandwidth: | 10 MHz min. @S11≤-10 dB |
| Noise Figure: | 1.5 |
| Outer Band Attenuation: | 3 dB max. |
| Supply Voltages: | 2.5~5.5V DC. |
| Current Consumption: | at 2.5V 6.6mA Typ. at 3.0V 8.6mA Typ. at 4.0V 12.6mA Typ. at 5.0V 16.6mA Typ. |
| Filter | 20dB 25dB @ fo+/- 50MHz 30dB 35dB @ fo+/- 100MHz * fo=1575.42MHz |

Overall Performance: (antenna element, LNA & coax cable)

| | |
|-------------------|---|
| Center Frequency: | 1575.42 +/- 1.023 MHz |
| Gain: | At 90° vertical to sky 30 ± 4.5dBi (cable loss) Note:1 Mounted on the 60mm x 60mm square ground plane |
| Noise Figure: | 1.5 max. |
| Axial Ratio: | 3 dB max. |
| Bandwidth: | 10 MHz min. @S11≤-10 dB |
| VSWR: | 2.0 max. |
| Output Impedance: | 50 ohm |

Environmental

| | |
|------------------------|---------------------|
| Operating Temperature: | -40°C~ +100°C. |
| Storage Temperature: | -40°C~ +100°C. |
| Relative Humidity: | 95% non-condensing. |
| Water Resistance: | 100% waterproof. |

| GSM / CDMA / 3G / | | FM |
|--------------------------|------------------------|----------------------|
| Frequency | 850/900/1800/1900/2170 | 88-108Mhz |
| VSWR | 2.0 | 3.5 |
| Impedence | 50Ω | |
| Cable type | RG174 | RG174 |
| Cable length | 5M | 5M |
| Connector | SMA Coding or Others | SMA Coding or Others |

* This specification is subject to change without prior notice

Data Updated: JUL.26, 2011

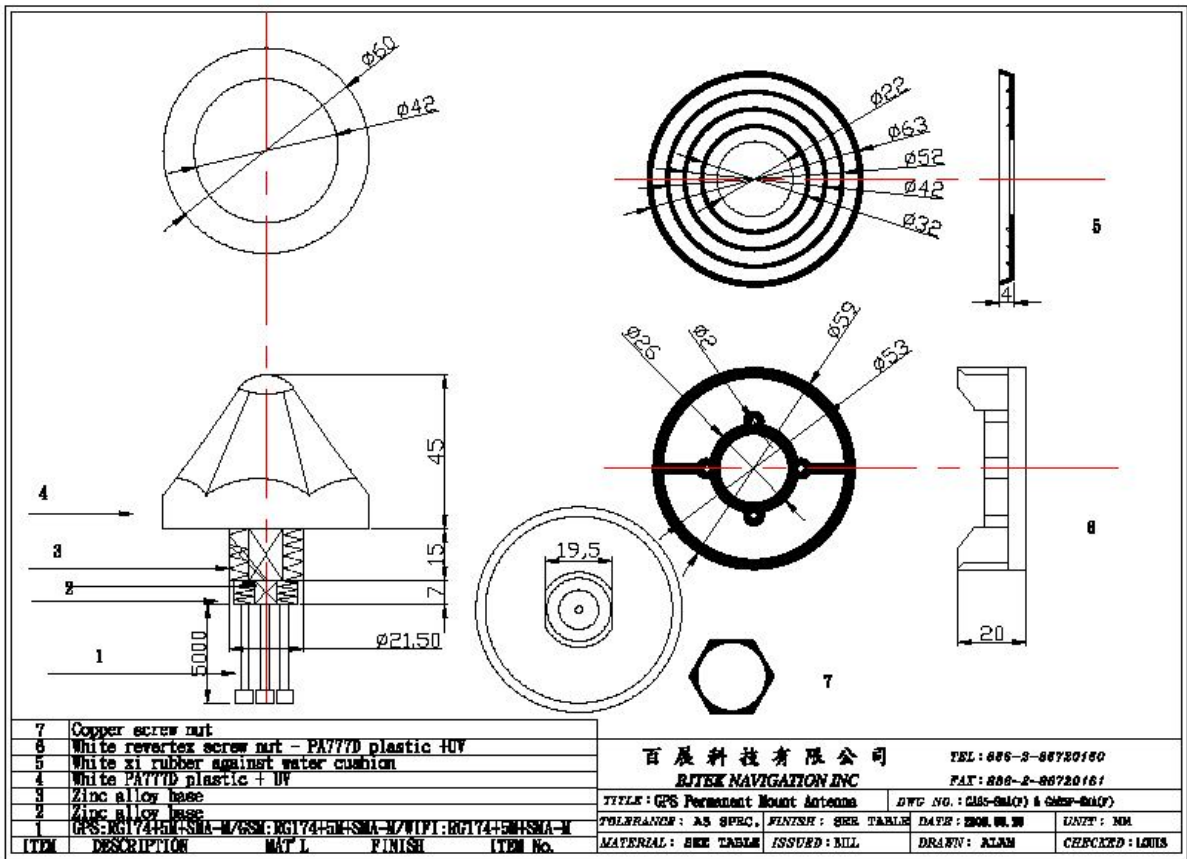

SUS L-Mounting

Madel : FB-6



Size :

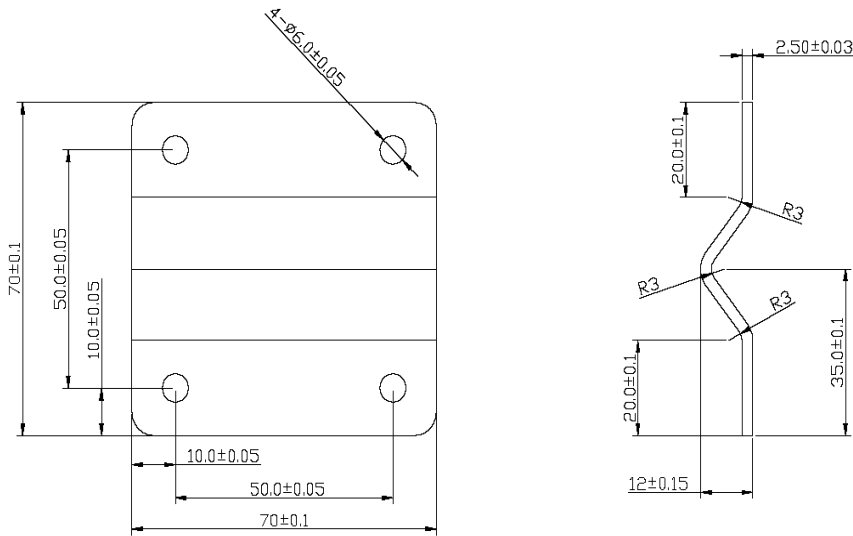
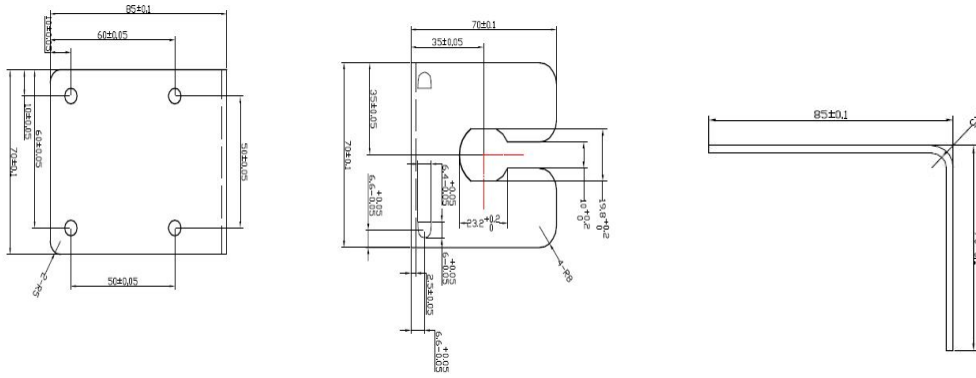

GPS TEST :

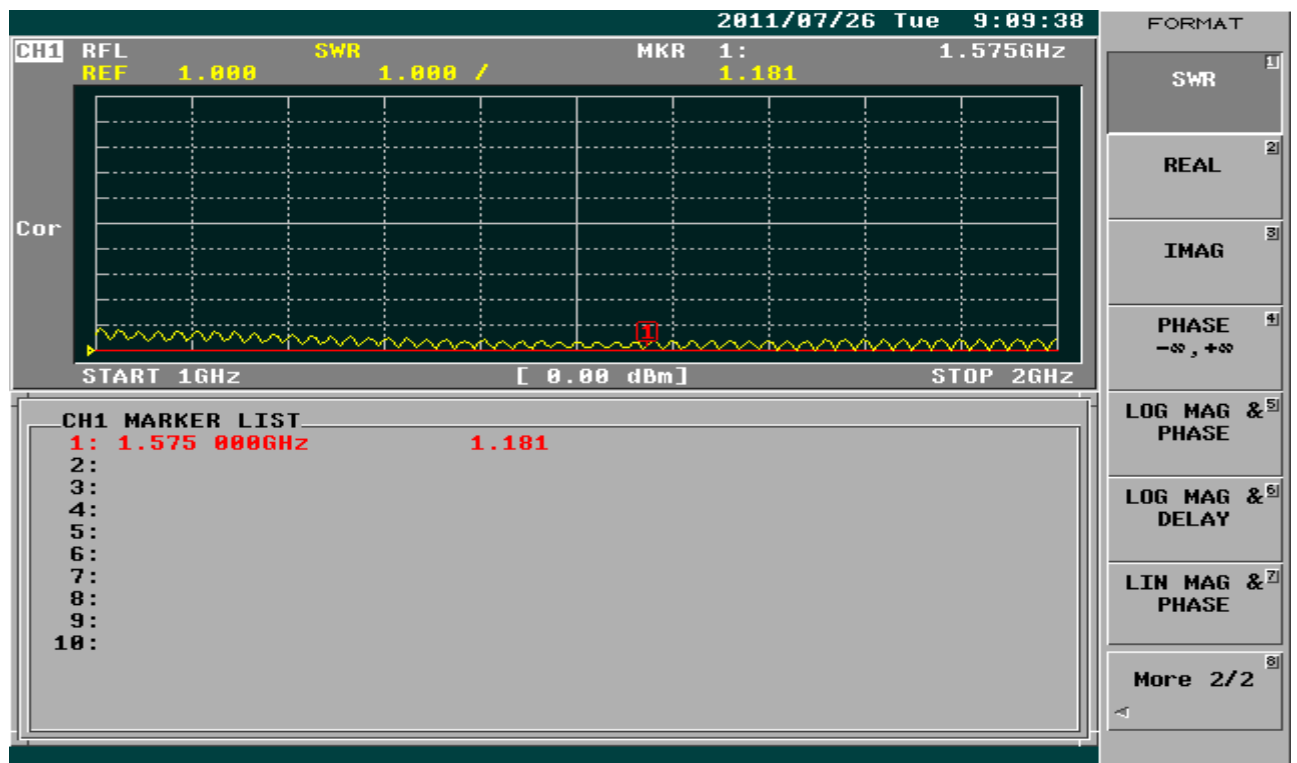

GSM TEST :

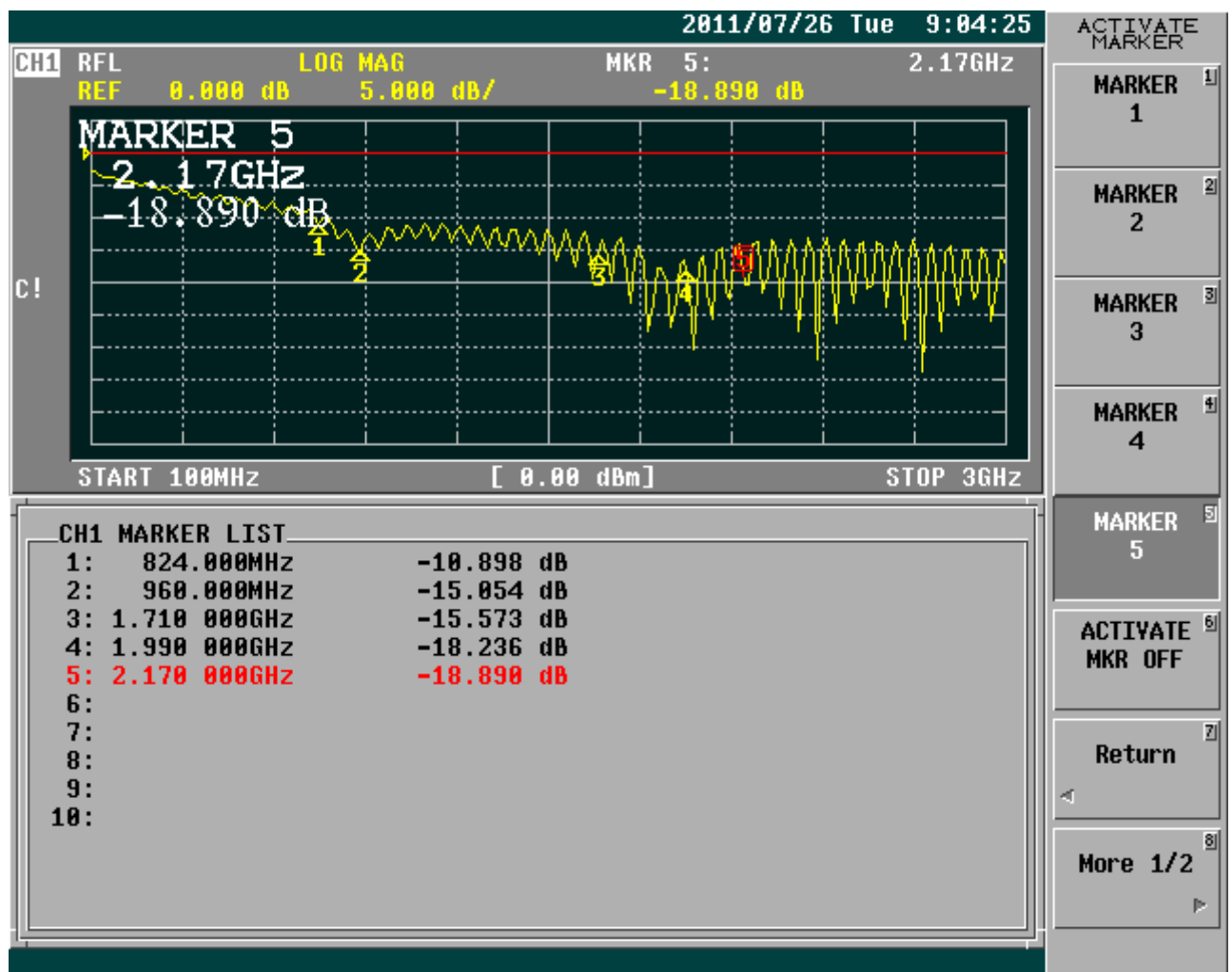
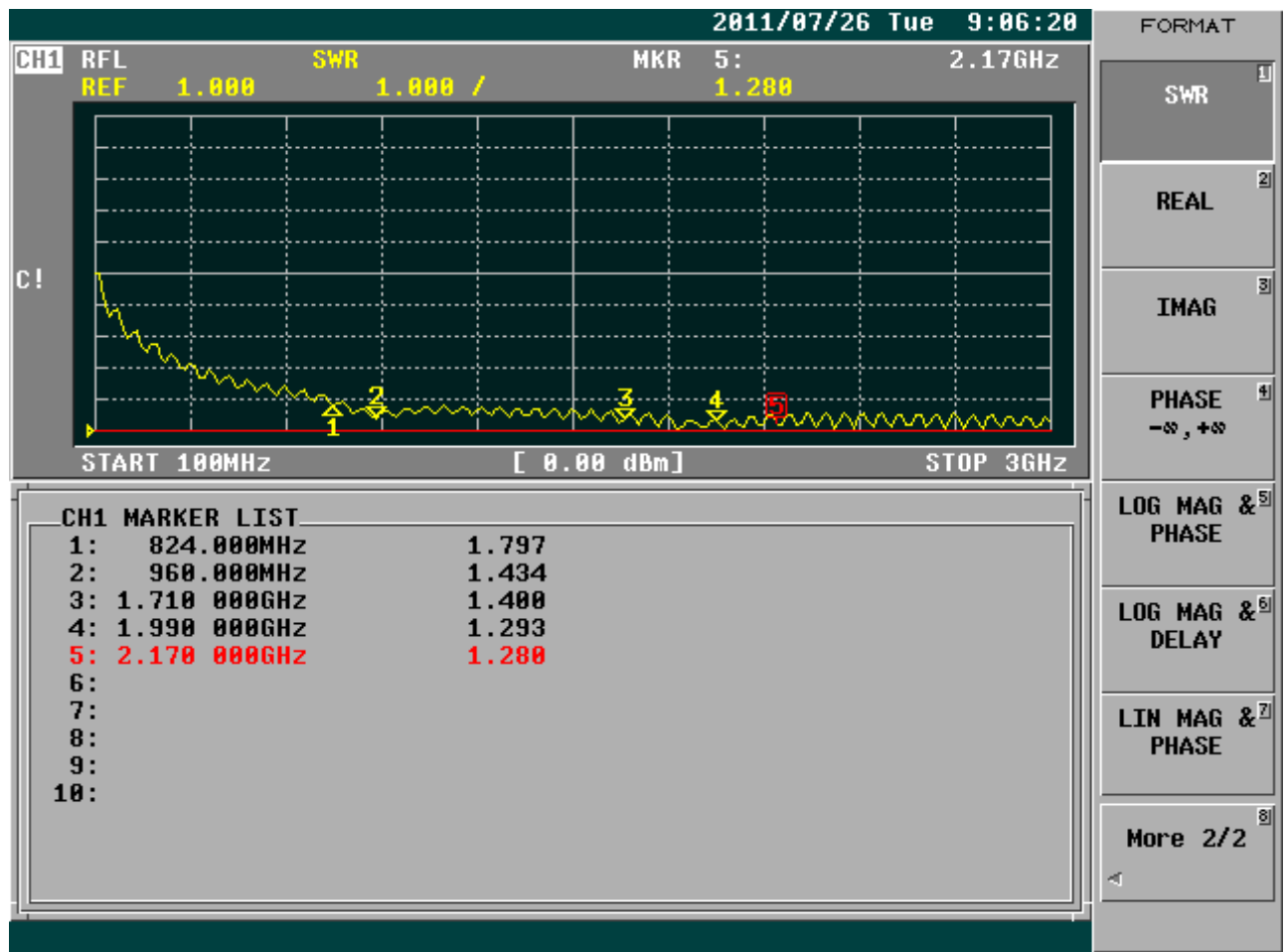

FM TEST :

