

Marine GPS/GLONASS & VHF Antenna

MODEL: GVA-650G

FOR Marine VHF Radio & AIS SYSTEM & Orbcomm



GPS Antenna Specifications: GA65G

PHYSICAL CONDITION	
Constructions:	Polycarbonate radome,detachable cable/connector for easy mount, rubber-O-ring between top radome and screw base for waterproof
Dimensions:	60mm(Dia.) x 45mm(H)
Weight:	65grams (w/o cable & connector).
Color:	Standard in ivory white, other colours available upon request.
Mounting:	Bulkhead mount with 0.8 inch threaded wing nut (standard accessory).
Cable & Connector	
RF cable:	TNC(M) +10 meter RG58 +BNC(M) (standard) other length (optional)
Pulling strength:	6 Kg @ 5sec. molded plastic on connector end for strain relief.
Connector	TNC(F)or SMA(F)
Antenna Element	
Center Frequency:	1575Mhz & 1596-1620 MHz
Polarization:	R.H.C.P. (Right Handed Circular Polarization).
Bandwidth	10 MHz min. @S11≤-10 dB, 24MHz typ. @S11<-8dB
Gain @ 10° Elevation:	2 dBi typical.
Axial Ratio:	3 dB max.
Output VSWR:	1.5 max
Output Impedance:	50 ohm
Low Noise Amplifier	
Power Gain:	1570 Mhz : 29db typ 1620 Mhz : 16db typ
Bandwidth:	50 MHz min.
Noise Figure:	1.5 typ
Outer Band Attenuation:	20 dB min. @ Fo +/-50 Mhz.

Supply Voltages:	2.3~5.5V DC.
Current Consumption:	2.5V : 6.6mA Typ. 3V: 8.6mA Typ. 4V: 12.6mA Typ. 5V: 16.6mA Typ.
Output Impedance:	50W ohm
Overall Performance: (antenna element, LNA & coax cable)	
Center Frequency:	1570 ~1620 Mhz.
Gain:	At 90° vertical to sky 30 ± 4.5dBi (cable loss) Note:1 Mounted on the 60mm x 60mm square ground plane
Noise Figure:	2.0 max.
Axial Ratio:	3 dB max.
Bandwidth:	10MHz min.
VSWR:	2.0 max.
Output Impedance:	50W ohm
Environmental	
Operating Temperature:	-40°C~ +85°C.
Storage Temperature:	-40°C~ +90°C.
Relative Humidity:	95% non-condensing.
Water Resistance:	100% waterproof.

Marine VHF Antenna Specifications: MVA-1400B

Marinr VHF ANTENNA	
Fr :	156 ~ 165 Mhz
Gain:	3 ~6dB
Configuration :	1/2 wave
VSWR	2.0:1
Impedence:	50 ohm
Connector:	PL259(F) or N(F)
Ground	without
Dimension:	1380mm
Weight:	1Kg

* This specification is subject to change without prior notice

Data Updated: FEB.05, 2010



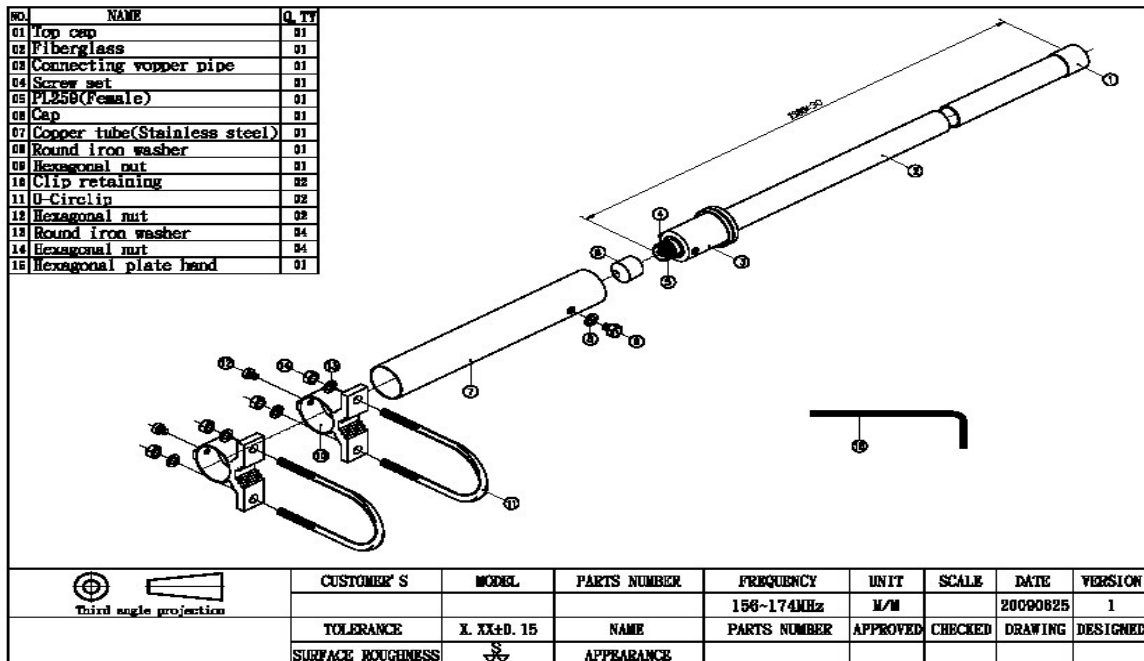
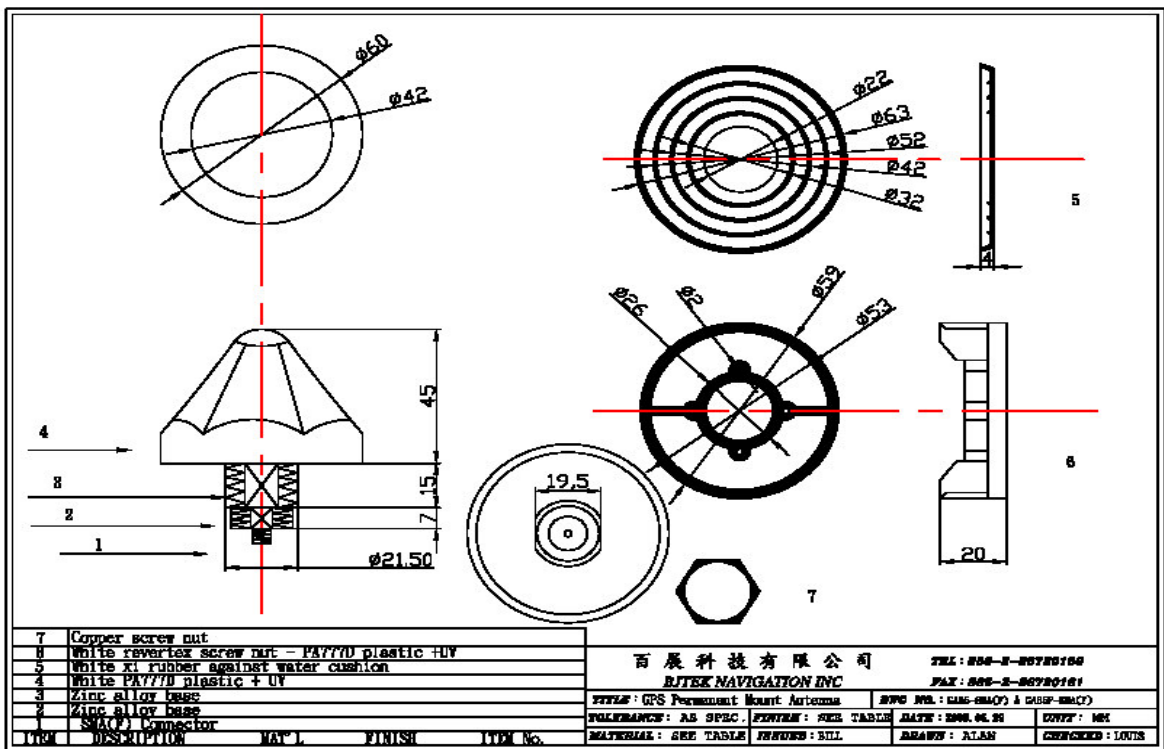

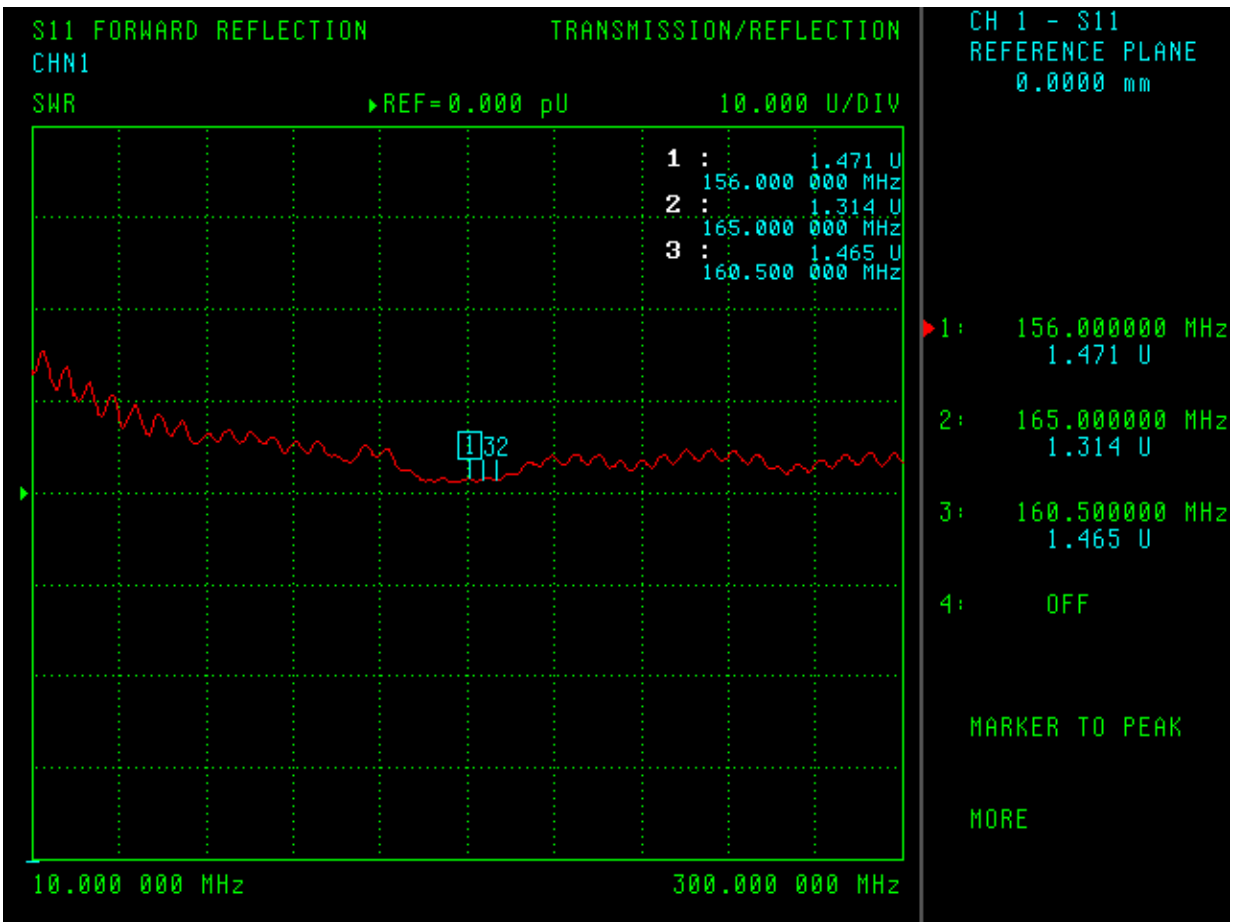
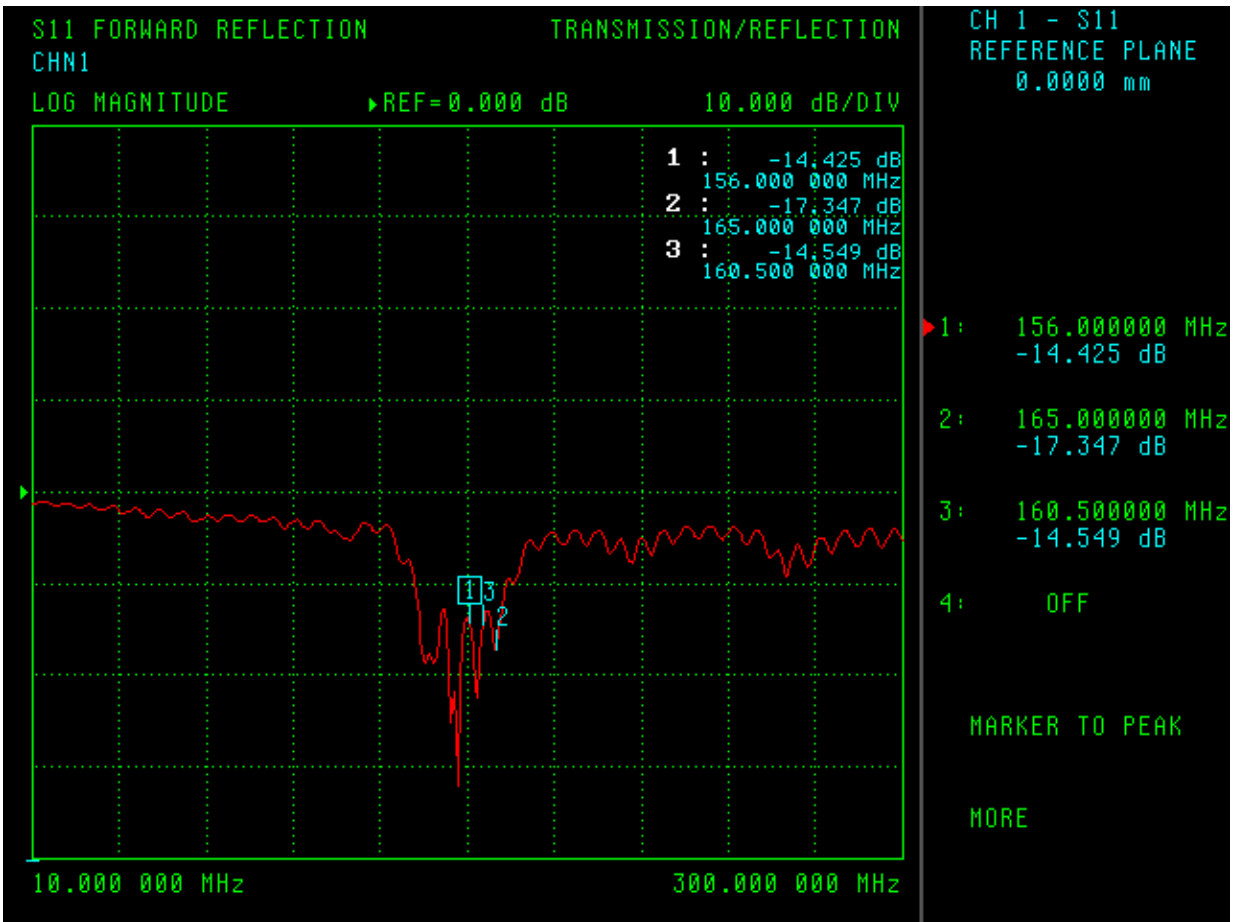

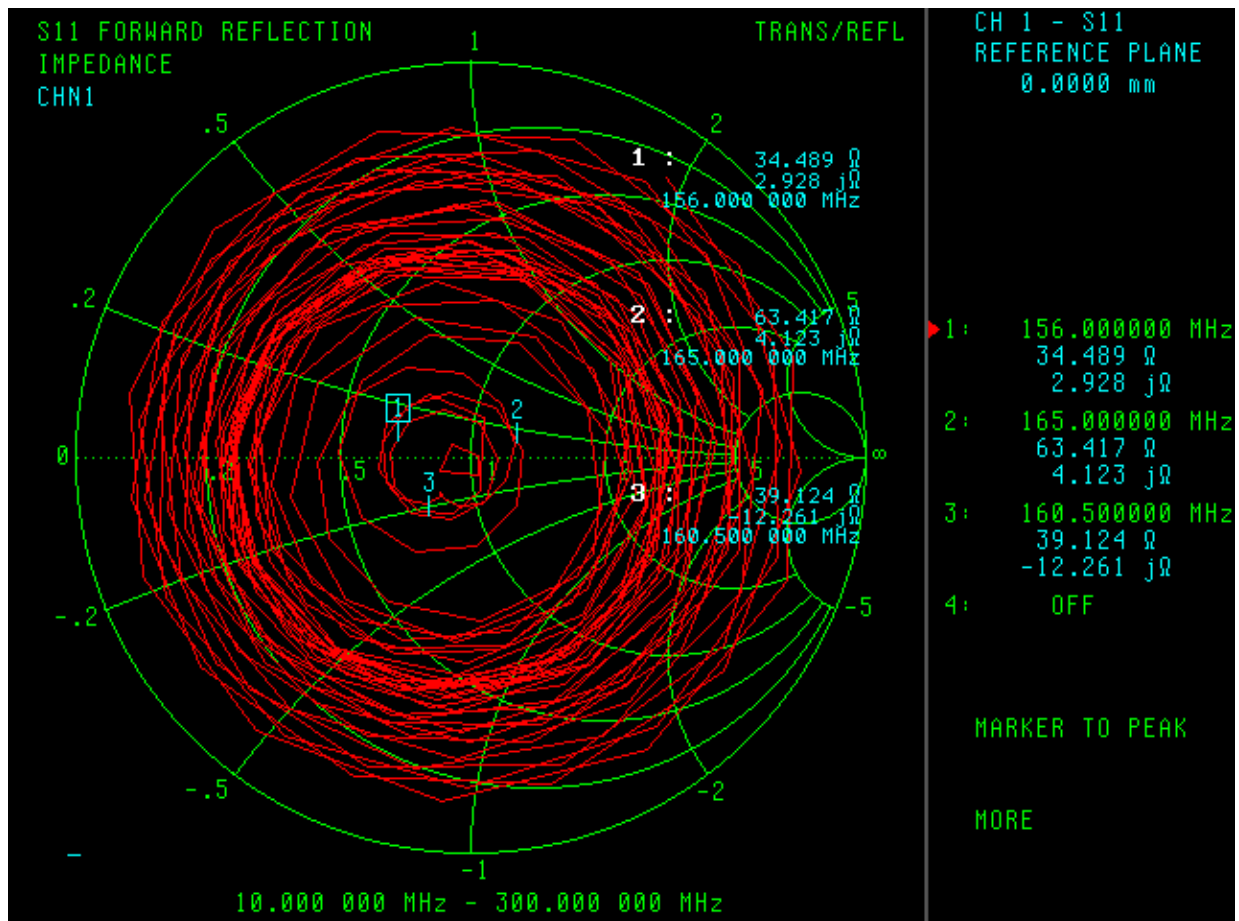

FB6 : SUS Base mounting

