

Marine Combo GPS / VHF Antenna

MODEL: GVA-150A

(Low Input Voltage)

AIS system & boat manages the double frequency GPS/VHF Antenna



Specifications:

PHYSICAL CONDITION	
Constructions:	Polycarbonate radome, rubber-O-ring between top radome and screw base for waterproof
Dimensions:	47.2mm(Dia.) x 38mm(H)
Weight:	240grams (with 5M cable & connector).
Color:	Standard in Black
Mounting:	Bulkhead mount with 0.46 inch threaded wing nut.
Cable & Connector	
RF cable:	5 meter RG174/U (standard) other length (optional)
Pulling strength:	6 Kg @ 5sec. molded plastic on connector end for strain relief.
Connector available:	SMA/SMB/MCX/MMCX/GT5/FME---
Optional:	Universal Connector Adapter (FME to TNC/BNC/SMA/SMB/MCX)
Antenna Element	
Center Frequency:	1575.42 MHz +/-1.023 MHz
Polarization:	R.H.C.P. (Right Handed Circular Polarization).
Absolute Gain @ Zenith:	+5 dBi typical.
Gain @ 10° Elevation:	-1 dBi typical.
Axial Ratio:	3 dB max.
Output VSWR:	1.5 max
Output Impedance:	50 ohm
Low Noise Amplifier	
Center Frequency:	1575.42 MHz

Power Gain:	28db +/-4.5db
Bandwidth:	10MHz min.
Noise Figure:	1.5 min.
Outer Band Attenuation:	3 dB max.
Supply Voltages:	2.5~5.5V DC
Current Consumption:	2.5V : 6.6mA Typ. 3V: 8.6mA Typ. 4V: 12.6mA Typ. 5V: 16.6mA Typ.
Output Impedance:	50W ohm
Overall Performance: (antenna element, LNA & coax cable)	
Center Frequency:	1575.42 Mhz.
Gain:	At 90° 30 ± 4.5dBi-(cable loss) Note:1 Mounted on the 60mm x 60mm square ground plane
Noise Figure:	2.0 max.
Axial Ratio:	3 dB max.
Bandwidth:	2MHz min.
VSWR:	2.0 max.
Output Impedance:	50W ohm
Environmental	
Operating Temperature:	-40°C~ +85°C.
Storage Temperature:	-50°C~ +90°C.
Relative Humidity:	95% non-condensing.
VHF Annt	
Frequency	156-165Mhz (AIS System)
VSWR	<2.0 Max
Impedence	50Ω
Cable type	RG174
Cable length	5M
Connector	SMA Coding or Others
Power	5~10W

* This specification is subject to change without prior notice

PS. Car Shell drill the hole OD12mm, When test must lock on the sheet iron

NO.	NAME	FINISH	Q, TY
01	Whip	Black	
02	Top cap	Black	01
03	Base	Black	01
04	Screw set	Nickel plating	01
05	RG-174 A/U Cable	Black	02
06	PL-259(Male)	Nickel plating	01
07	Heat-shrink tube	Black	02
08	BNC 180'(Male)	Nickel plating	01
09	Washer	Nickel plating	01
10	Nut hexagonal	Nickel plating	01

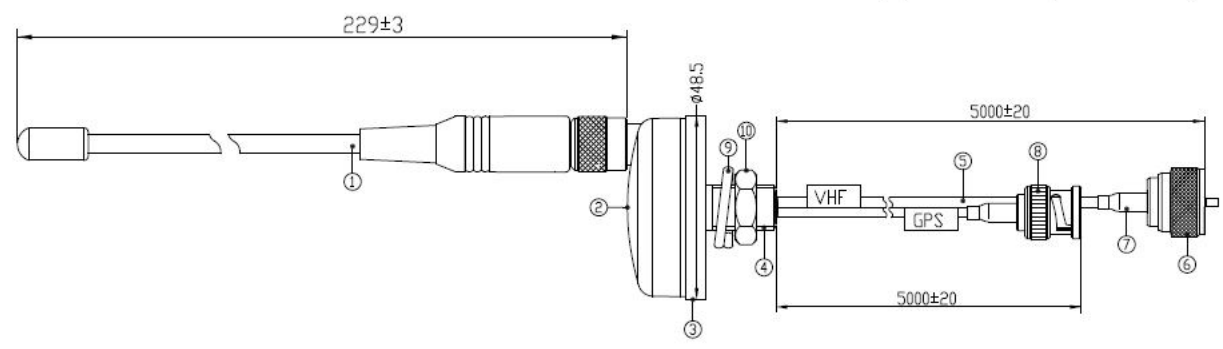

Third angle projection	CUSTOMER'S	MODEL	PARTS NUMBER	FREQUENCY	UNIT	SCALE	DATE	VERSION
					1575.42MHz 156-165MHz	M/M		20110607
	TOLERANCE	X.XX±0.15	NAME	PARTS NUMBER	APPROVED	CHECKED	DRAWING	DESIGNED
	SURFACE ROUGHNESS	\sqrt{S}	APPEARANCE					

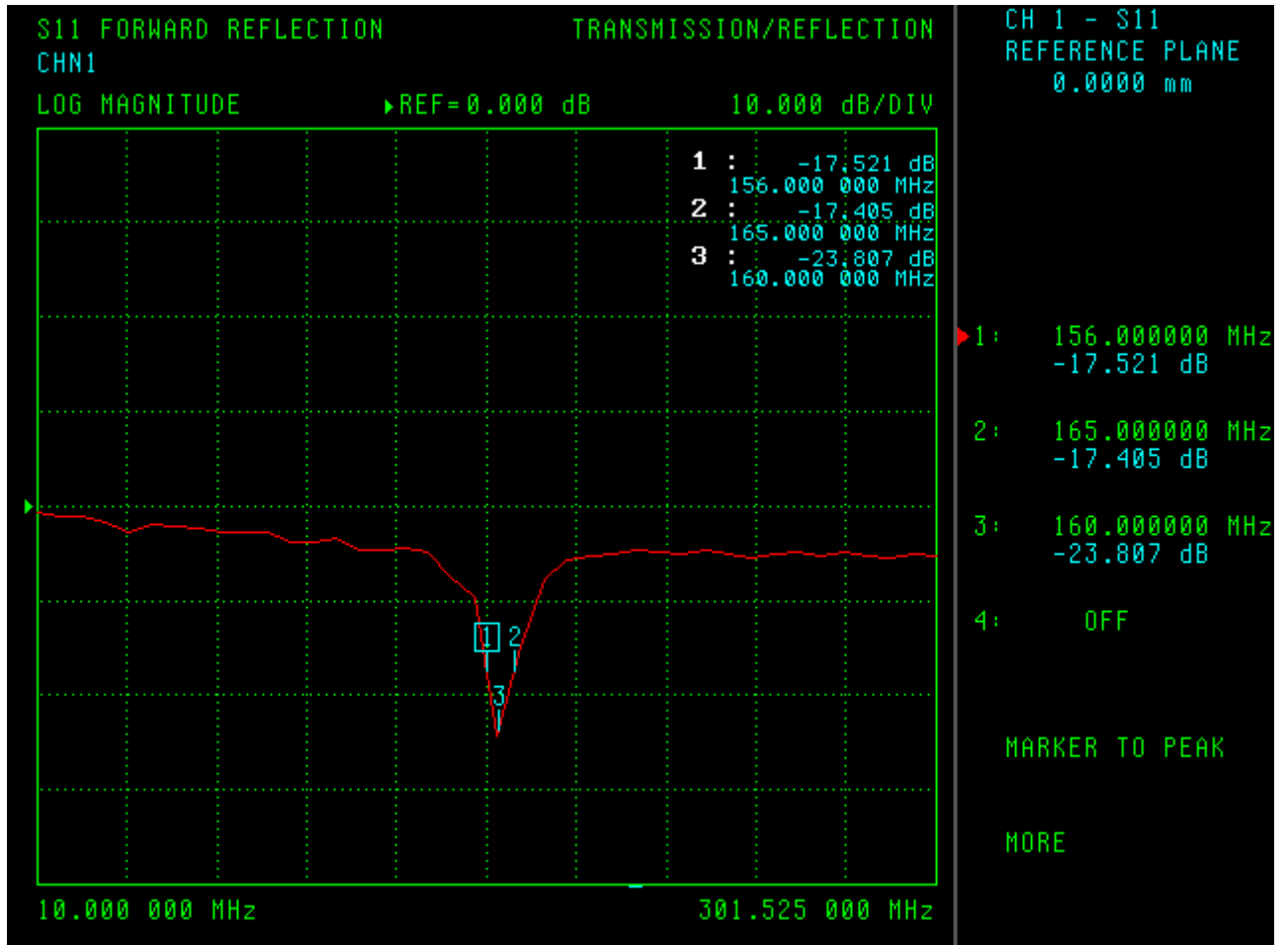

S11 FORWARD REFLECTION
CHN1

TRANSMISSION/REFLECTION

CH 1 - S11
REFERENCE PLANE
0.0000 mm

SWR

REF=0.000 pU

10.000 U/DIV

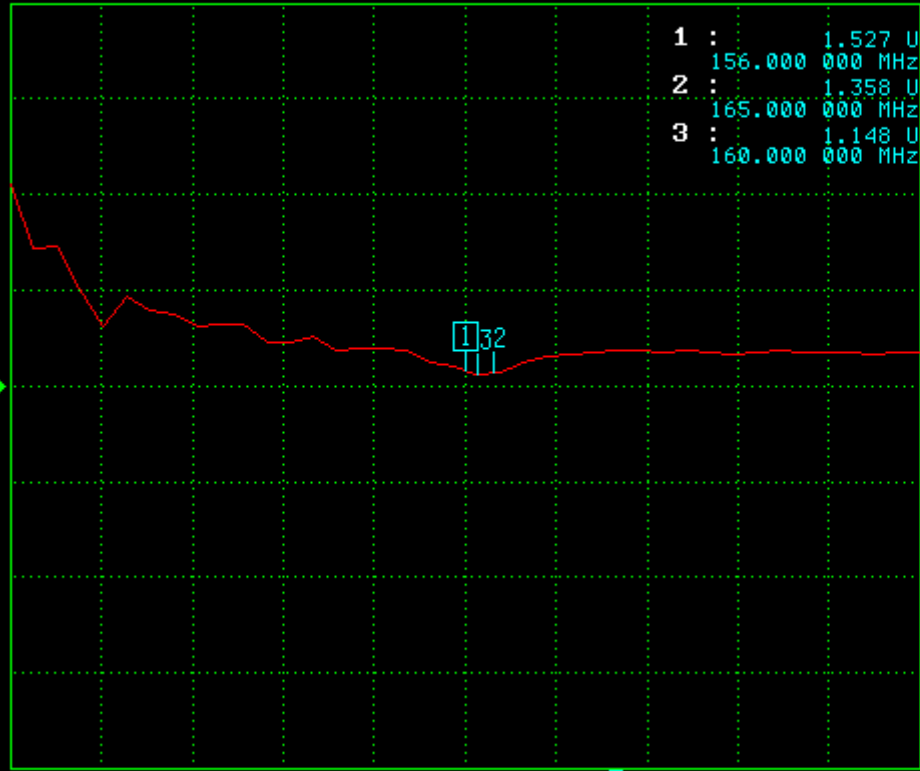

1 : 1.527 U
156.000 000 MHz
2 : 1.358 U
165.000 000 MHz
3 : 1.148 U
160.000 000 MHz

1: 156.000000 MHz
1.527 U
2: 165.000000 MHz
1.358 U
3: 160.000000 MHz
1.148 U
4: OFF

MARKER TO PEAK

MORE

10.000 000 MHz

301.525 000 MHz