

OUTSIDE GPS/GSM Antenna

MODEL: GMA-650P

FOR Base Antenna or Marine GPS/GSM System



GPS Antenna Specifications: GA65P

Specifications	
Antenna Element	
Center Frequency	1575.42 MHz +/-1.023 MHz
Polarization	R.H.C.P. (Right Handed Circular Polarization)
Absolute Gain @ Zenith	+5 dBi typical Based on 70x70mm ground plane
Gain @ 10° Elevation	-1 dBi typical
Axial Ratio	3 dB max.
Output VSWR	1.5:1 Typ.
Output Impedance	50 ohm
Low Noise Amplifier	
Center Frequency	1575.42 MHz +/- 1.023 MHz
Power Gain	38db(3V) / 45db(5V) (Without cable +25°C±10°C)
Bandwidth	10 MHz min.
Noise Figure	1.6 Typ.
Outer Band Attenuation	20 dB min. @ Fo +/-50 MHz
Supply Voltages	3.0~5.0V DC
Current Consumption	21mA@ 3.0V DC,25mA@ 5.0V DC
VSWR	1.5 max.
Output Impedance	50 ohm
Overall Performance: (antenna element, LNA & coax cable)	
Center Frequency	1575.42 MHz
Gain	38db(3V) / 45db(5V) (Without cable +25°C±10°C)
Noise Figure	2.0 max.
Bandwidth	10 MHz min.
Axial Ratio	3 dB max.
VSWR	1.5 max.
Output Impedance	50 ohm
Environmental Conditions	
Operating Temperature	-30°C to +80°C
Storage Temperature	-40°C to +100°C

Relative Humidity	40% to 95% non-condensing
Water Resistance	100% waterproof
Physical Constructions	
Dimensions	Antenna : 60mm(Dia.) × 45mm(H)
Weight	65 grams (without cable)
Standard Mounting	Bulkhead mount with 0.8 inch threaded wing nut (standard accessory).
Cable & Connector	
RF Connector	SMA(F) or TNC(F)
Cable Pulling strength	6 Kg @ 5sec. molded plastic on connector end for strain relief.

Marine GSM Antenna Specifications: GSM-100

Frequency range:	850/900/1800/1900/2170Mhz
Gain:	7~9dBi
V.S.W.R:	<2.0
Impedence:	50 ohm
Connector:	N Type Female
Dimension:	756mm +/-10 x OD20mm
Weight:	0.76Kg
Polarization :	vertical
Power handling :	50W
Colour :	white
Rated wind velocity :	60m/s
Working Temperature :	-40~60°C
Lightning Protection :	Direct Ground

* This specification is subject to change without prior notice

Data Updated: FEB.05, 2010



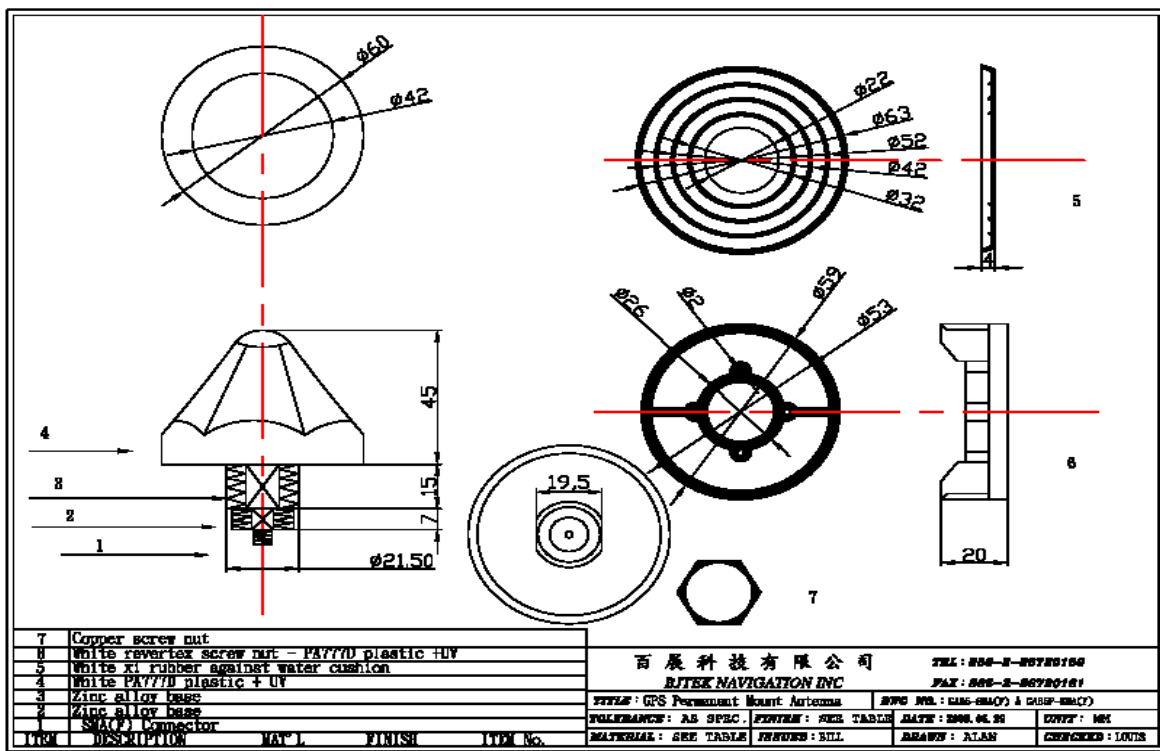

NO.	NAME	Q, TY
01	Body	01
02	Cap	01
03	Tube aluminium	01
04	Round iron washer	01
05	Hexagonal nut	01
06	Clip retaining	02
07	U-Circlip	02
08	Hexagonal nut	02
09	Round iron washer	04
10	Hexagonal nut	04
11	Hexagonal plate hand	01

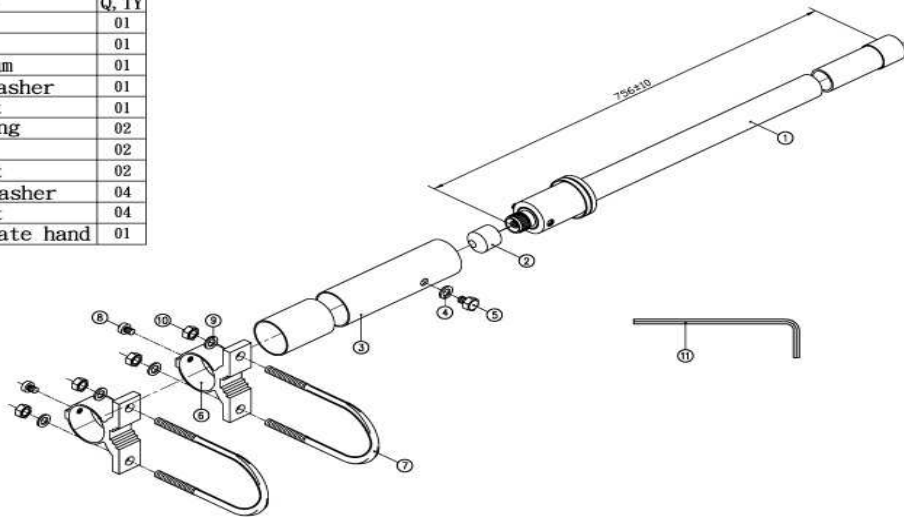

 Third angle projection	CUSTOMER'S	MODEL	PARTS NUMBER	FREQUENCY	UNIT	SCALE	DATE	VERSION
				800/900/1800/1900/2170MHz	M/M		20070903	1
	TOLERANCE	X. XX±0.15	NAME	PARTS NUMBER	APPROVED	CHECKED	DRAWING	DESIGNED
	SURFACE ROUGHNESS	S VV	APPEARANCE					

S11 FORWARD REFLECTION
CHN1

TRANSMISSION/REFLECTION

LOG MAGNITUDE

REF=0.000 dB

10.000 dB/DIV

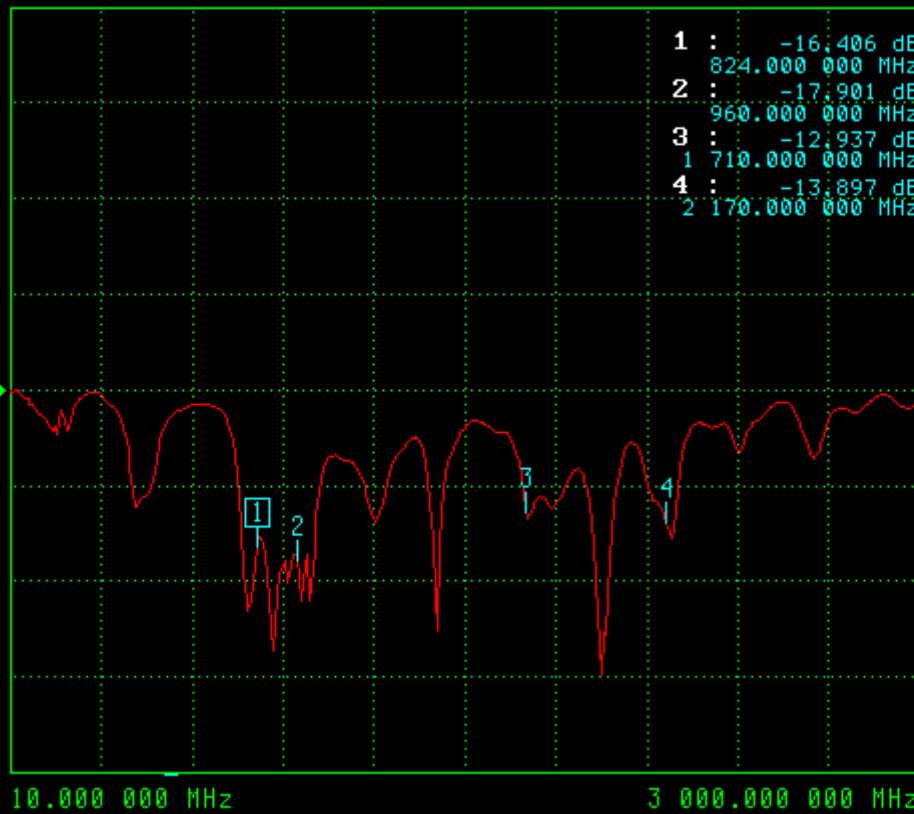

CH 1 - S11
REFERENCE PLANE
0.0000 mm

- 1: 824.000000 MHz
-16.406 dB
- 2: 960.000000 MHz
-17.901 dB
- 3: 1.710000000 GHz
-12.937 dB
- 4: 2.170000000 GHz
-13.897 dB

MARKER TO PEAK

MORE

S11 FORWARD REFLECTION
CHN1

TRANSMISSION/REFLECTION

SWR

REF=0.000 pU

10.000 U/DIV

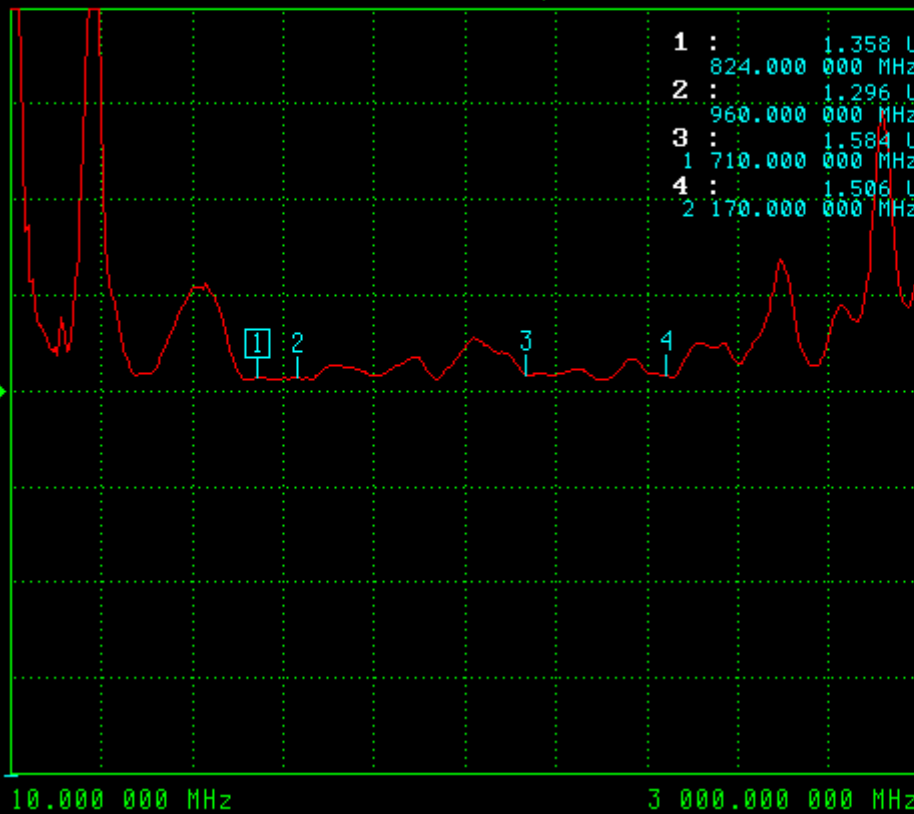

CH 1 - S11
REFERENCE PLANE
0.0000 mm

- 1: 824.000000 MHz
1.358 U
- 2: 960.000000 MHz
1.296 U
- 3: 1.710000000 GHz
1.584 U
- 4: 2.170000000 GHz
1.506 U

MARKER TO PEAK

MORE

