

Vehicle Locating & Marine Small

GPS/ GLONASS Antenna

MODEL: GA-62G

Small size and ruggedness, demand of vehicle locating and marine navigation GPS/ GLONASS antenna that will sustain harsh environment.



- Low noise figure
- Fully weather proof.
- Ultra-high Sensitivity
- Compact construction
- Excellent temperature stability

Specifications:

PHYSICAL CONDITION	
Constructions:	Polycarbonate radome, detachable cable/connector for easy mount, rubber-O-ring between top radome and screw base for waterproof
Dimensions:	60mm(Dia.) x 18.5mm(H)
Weight:	65grams (w/o cable & connector).
Color:	Standard in ivory white, other colours available upon request.
Mounting:	Bulkhead mount with 0.8 inch threaded wing nut (standard accessory).
Cable & Connector	
RF cable:	TNC(M) +10 meter RG58 +BNC(M) (standard) other length (optional)
Pulling strength:	6 Kg @ 5sec. molded plastic on connector end for strain relief.
Connector	TNC(F)
Antenna Element	
Center Frequency:	1575Mhz & 1596-1610 MHz
Polarization:	R.H.C.P. (Right Handed Circular Polarization).
Bandwidth	10 MHz min. @S11≤-10 dB, 24MHz typ. @S11<-8dB
Gain @ 10° Elevation:	2 dBi typical.
Axial Ratio:	3 dB max.
Output VSWR:	1.5 max
Output Impedance:	50 ohm
Low Noise Amplifier	
Power Gain:	1570 Mhz : 29db typ 1610 Mhz : 29db typ

Bandwidth:	50 MHz min.
Noise Figure:	1.5 typ
Outer Band Attenuation:	20 dB min. @ Fo +/-50 Mhz.
Supply Voltages:	2.3~5.5V DC.
Current Consumption:	2.5V : 6.6mA Typ. 3V: 10.6mA Typ. 4V: 14.6mA Typ. 5V: 20.6mA Typ.
Output Impedance:	50W ohm
Overall Performance: (antenna element, LNA & coax cable)	
Center Frequency:	1570 ~1610 Mhz.
Gain:	At 90° vertical to sky 30 ± 4.5dBi (cable loss) Note:1 Mounted on the 60mm x 60mm square ground plane
Noise Figure:	2.0 max.
Axial Ratio:	3 dB max.
Bandwidth:	10MHz min.
VSWR:	2.0 max.
Output Impedance:	50W ohm
Environmental	
Operating Temperature:	-40°C~ +85°C.
Storage Temperature:	-40°C~ +90°C.
Relative Humidity:	95% non-condensing.
Water Resistance:	100% waterproof.

* This specification is subject to change without prior notice

Data Updated: Sep.10, 2009



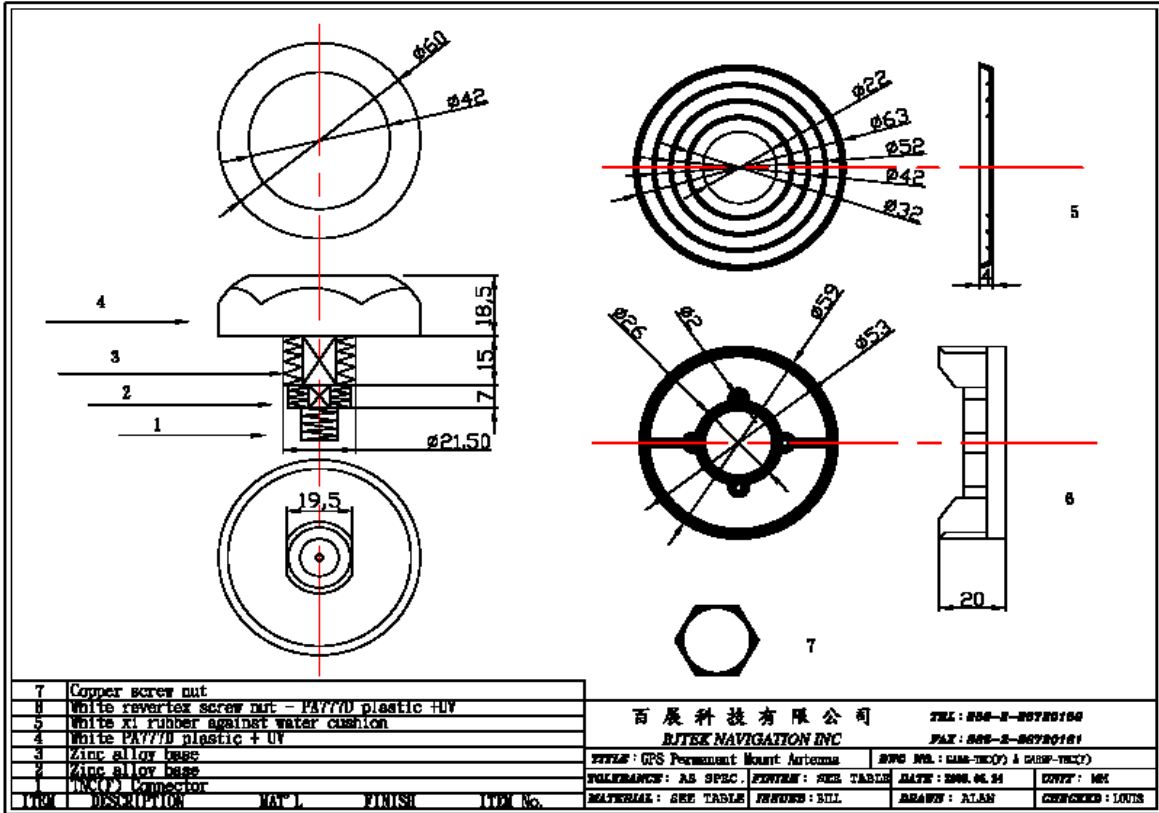

7	Copper screw nut			
6	White revertax screw nut - PA770 plastic TUV			
5	White XT rubber against water cushion			
4	White PA770 plastic + UV			
3	Zinc alloy base			
2	Zinc alloy base			
1	IN(T) Connector			
ITEM	DESCRIPTION	MAT'L	FINISH	ITEM No.

百展科技有限公司		TEL: 886-2-88780188	
BUJEX NAVIGATION INC		FAX: 886-2-88780181	
PTNOS: GPS Permount Mount Antenna		BWC NO: 648-7800) & 648P-7800)	
POLYMER: AS SPEC		FINISH: SEE TABLE	
DATE: 2008.06.24		DWT: MK	
MATERIAL: SEE TABLE		FINISH: BIL	
		DRAWN: ALAN	
		CHECKED: LOUIS	