

RFID ANTENNA

Model : TH-915F



1. GENERAL DESCRIPTION

Model No
TH915F-SMA90(M)

1.1 Electrical Properties

Parameter	Description
Frequency Band	860/902/928/960 MHz
Nominal Impedance	50 ohm
Polarization	Vertical
Return Loss	Please See Data-1
V.S.W.R	2.0 : 1
Note: Gain includes the cable loss	

1.2 Mechanical Properties

Parameter	Description
Antenna Type	External Antenna
Touch Type	Screw Type
Connector Type	SMA 90° (Male)
Antenna Dimensions	160 mm ± 10
Antenna Color	Black
Operating Temperature Range	-20°C~+60°C
Storage Temperature Range	-30°C~+70°C

2. Appearance

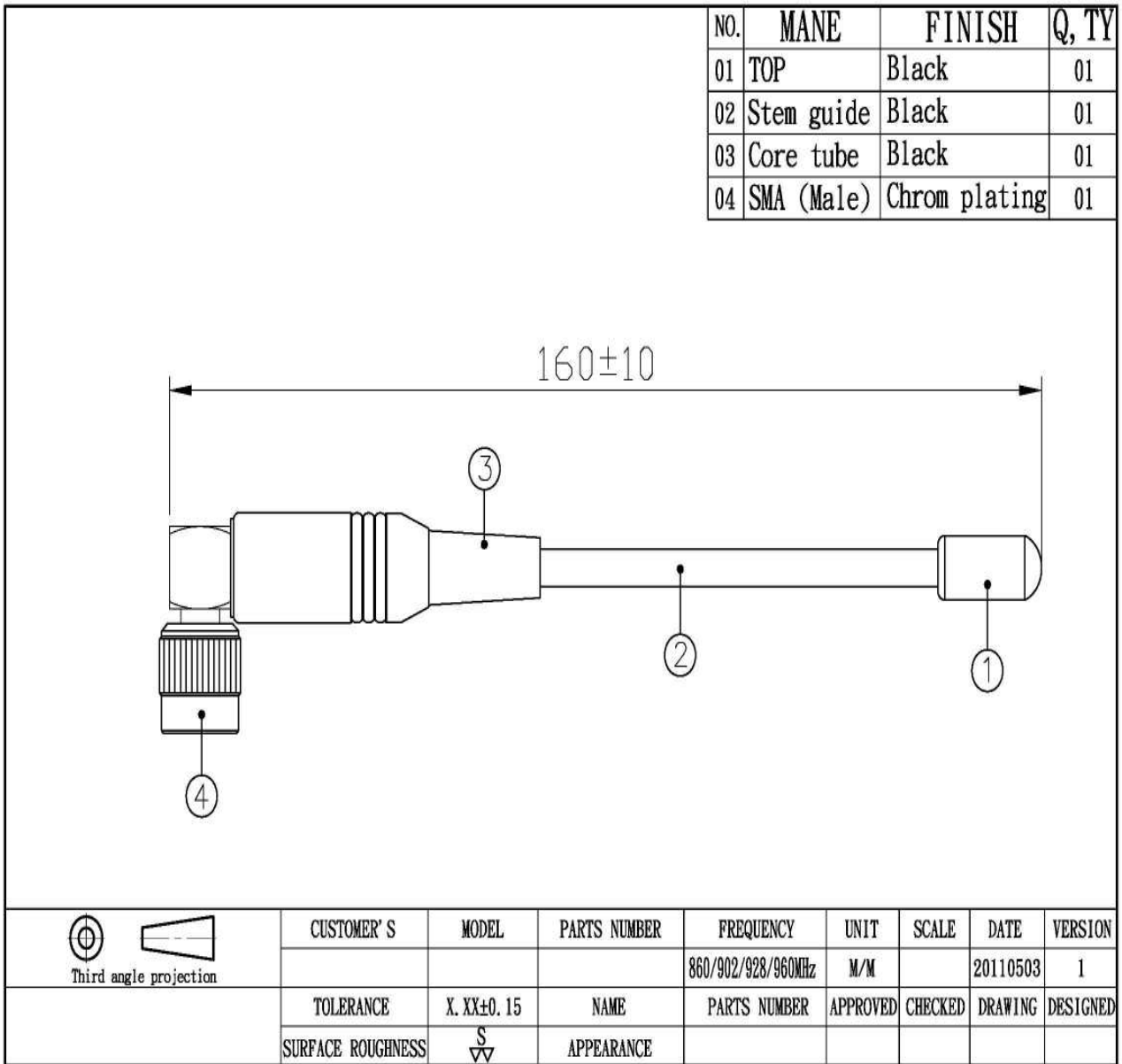

3. Frequency

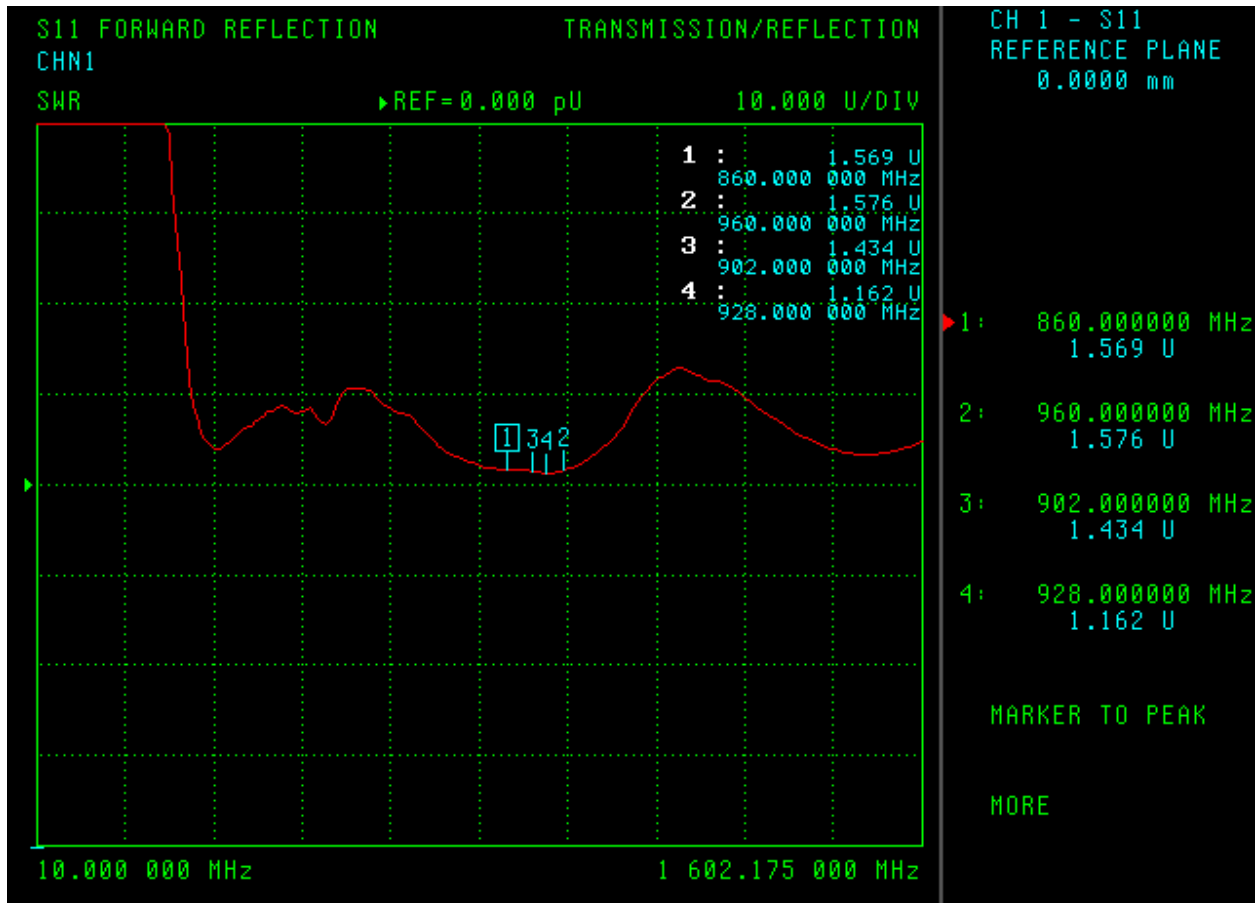
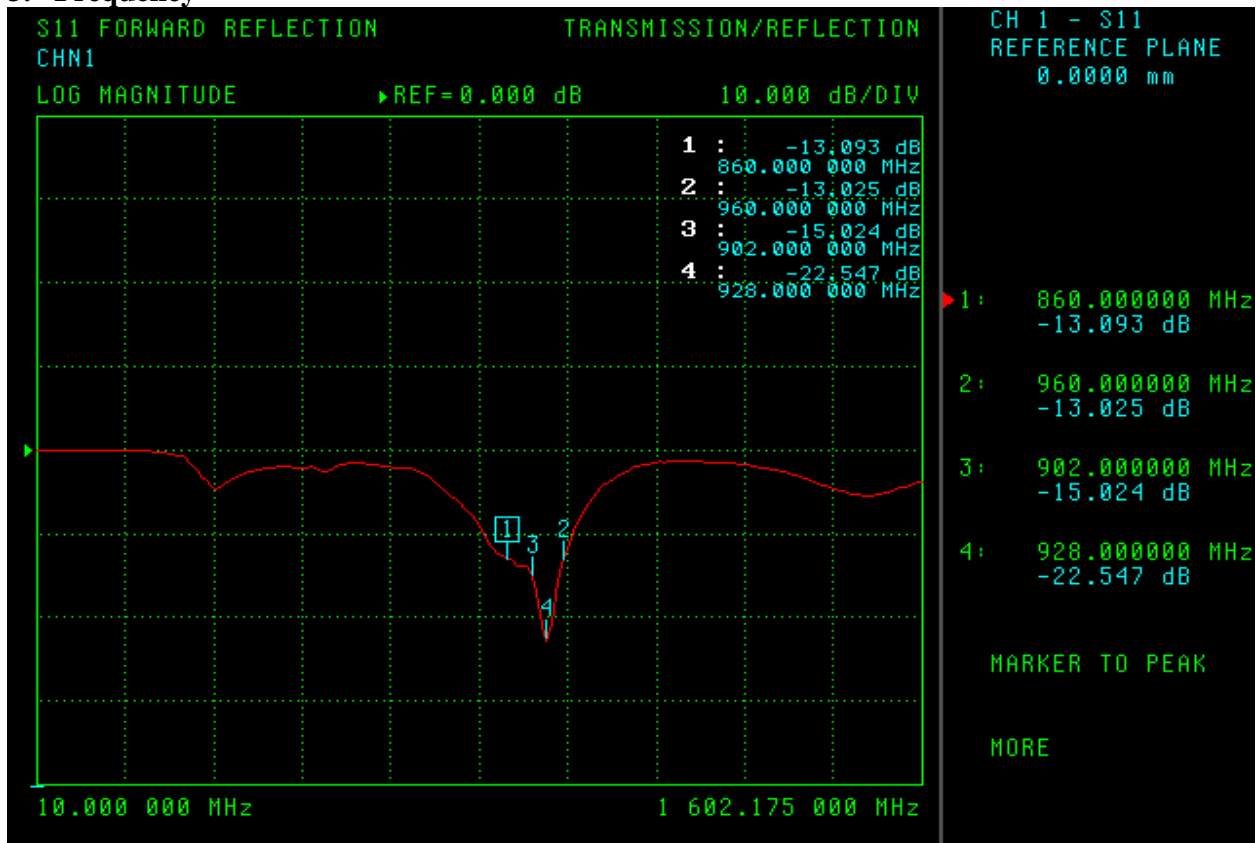

S11 FORWARD REFLECTION
IMPEDANCE
CHN1

TRANS/REFL

CH 1 - S11
REFERENCE PLANE
0.0000 mm

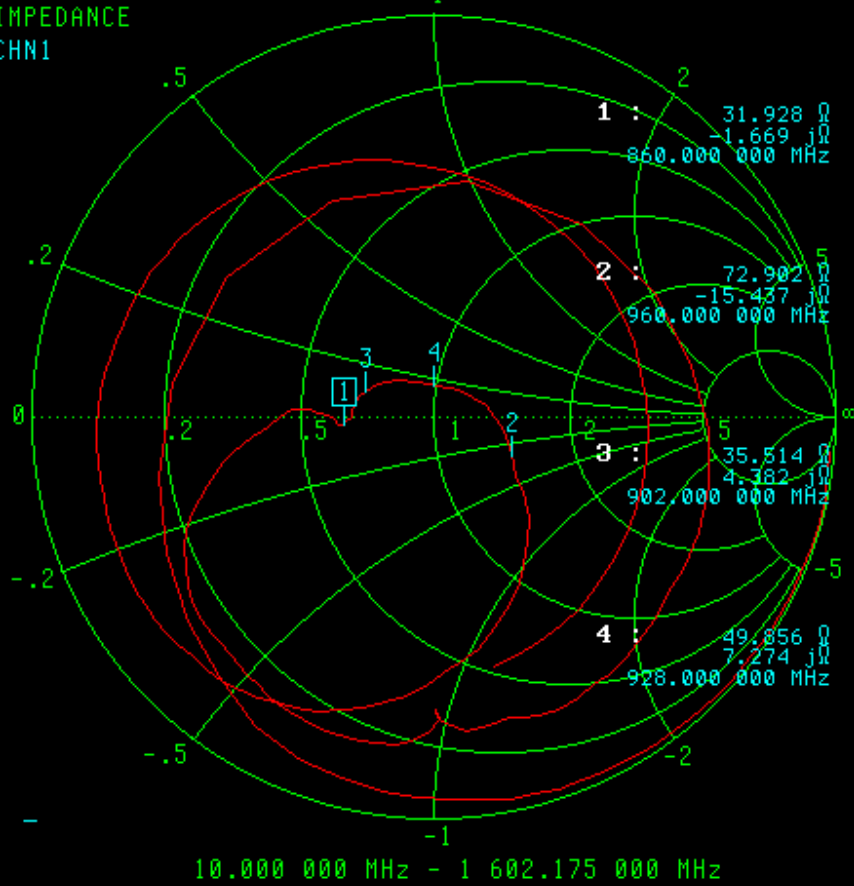

- 1: 860.000000 MHz
31.928 Ω
-1.669 $j\Omega$
- 2: 960.000000 MHz
72.902 Ω
-15.437 $j\Omega$
- 3: 902.000000 MHz
35.514 Ω
4.382 $j\Omega$
- 4: 928.000000 MHz
49.856 Ω
7.274 $j\Omega$

MARKER TO PEAK

MORE