

# RB1912S4

Ultra High Sensitivity SiRF StarIV GSD4e  
GPS Smart Antenna with Miniature  
Dimension

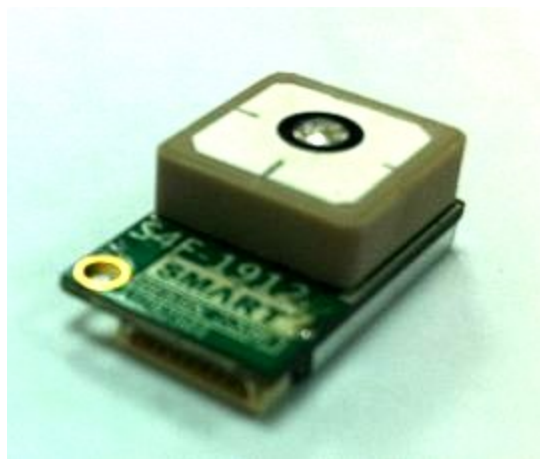

# Documentation History

<b>Revision</b>	<b>Description</b>	<b>Date</b>	<b>Remark</b>
V0.1	1912 release	OCT 2011	

# Content

Features.....	4
Block diagram.....	4
Technical Specifications.....	5
Pin Definition.....	6
Output NMEA Messages.....	7
Application Circuit.....	8
Packing handling.....	9
Ordering code.....	9

## Features

- ✓ 48 channel SiRF StarIV GSD4e positioning engine.
- ✓ Ultra high sensitivity to -159 dBm.
- ✓ SBAS (WAAS, MSAS, and EGNOS) support.
- ✓ Support 5Hz Update rate
- ✓ Supports UART interface.
- ✓ Ultra low power consumption. <10mW required for TricklePower™ mode
- ✓ Ultra miniature 19 x 12 mm dimension with 12x12x 4 mm patch antenna
- ✓ Operating temperature range: -40 to 85°C
- ✓ RoHS compliant (lead-free)

## Block diagram

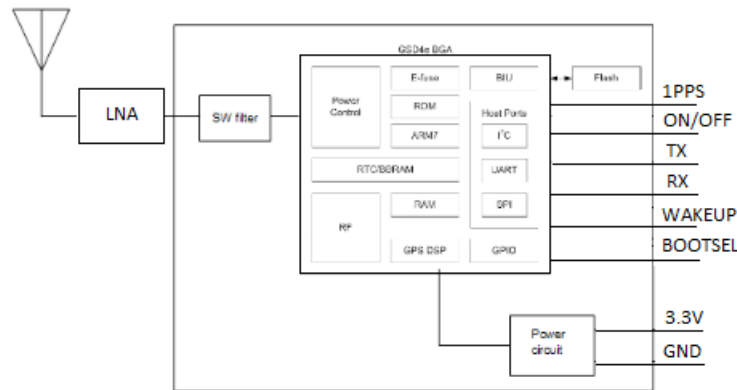

# Technical Specifications

## 1. Electrical

### Characteristics

1.1 Chip set	SiRF StarIV GSD4e9411	External Flash version
1.2 General	Frequency	L1, 1575.42MHz
	Channels, C/A code	48, 1.023 MHz chip rate, 8192 time/frequency search windows
1.3 Accuracy	Position	3 meters CEP
	Time	200 msec (1 PPS)
1.4 DGPS Accuracy	Position	2.5 meters CEP
1.5 Acquisition Rate	Reacquisition	< 1 sec, typical
	Cold start	32 sec, typical
	Cold start ( CGEE* )	Under 15 sec
	Hot start	1 sec, typical
1.6 Sensitivity	Tracking	-159dBm
	Navigation	-156dBm
	Autonomous Acquisition	-144dBm
1.7 Dynamic Condition	Altitude	18,288 meters (60,000 Feet) max.
	Velocity	515 meters /sec (1000 Knots) max.
1.8 Power	Main Power	3.3 VDC typical
	Supply current (Tracking)	45 mA (AVG)
	Supply current (Navigation)	42 mA (AVG)
	OFF mode	40 uA
1.9 Serial Port	Electrical interface	UART(defalut)
	Protocols	NMEA0183 v3.0
	Baud Rate	4800, 9600(default)

## 2. Environmental Characteristics

2.1 Temperature	Operating range	- 40 °C to + 85 °C
2.2 Mechanical dimensions	L x W x H	19.0 x 12.0 x 7.5 mm
2.3 Interface	I/O connector	8 pin

\*CGEE: Client Generated Extended Ephemeris

## 3 Antenna

Parameter	Specification
3.1 Antenna type	Passive or active antenna

## Dimension

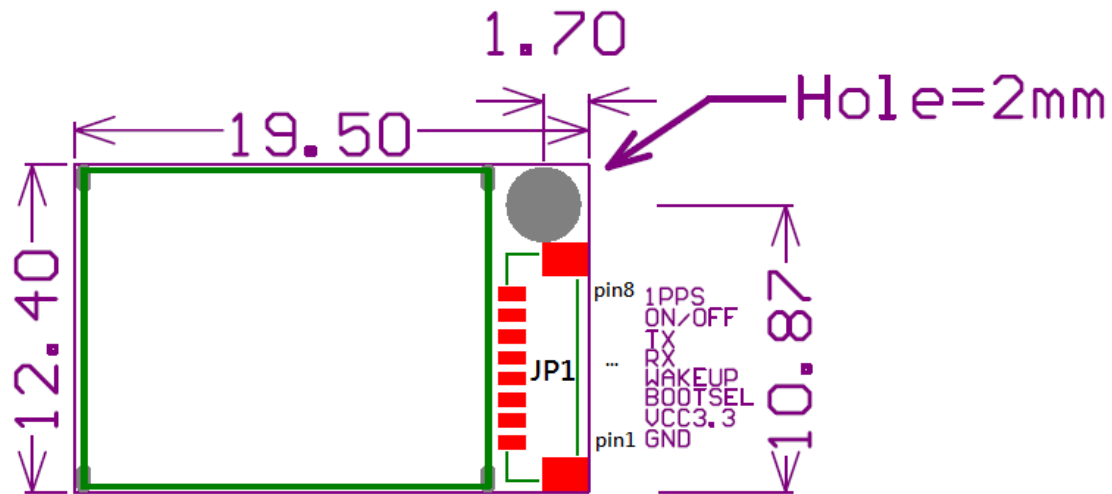

Bottom View

pitch: 0.8mm

## Pin Definition

Pin#	Name	Type	Description
1	GND	GND	Ground
2	VCC3.3	PWR	DC power input 3.3V (2.8~3.5V)
3	BOOTSET	Input	High Boot from Flash, Low Boot from serial port
4	WAKEUP	Output	“H” GPS in operational model, “L” GPS in low power model. GPS Wake up output for control of external LNA or active antenna, or can also enable an external regulator, e.g. battery to 1.8V for the main input to the switch-mode regulator when full current mode is entered.(1.8V)
5	Host Port - RXA	Input	UART RXA output (1.8~3.5V)
6	Host Port - TXA	Output	UART TXA output(same voltage level as pin7)
7	ON/OFF	Input	One high, low cycle to switch ON and OFF(1.8V)
8	1PPS	Output	Time plus 200msec (1.8V)

JP1 Connector Part number:

CSI-0882-XXXX from CST Master Electronic([www.cstconn.com](http://www.cstconn.com))

# Output NMEA Messages

## NMEA-0183 V3.0 Output Messages

NMEA Sentence	Description
GGA ( <b>default</b> )	Global Positioning System Fixed Data
GLL	Geographic Position - Latitude/Longitude
GSA ( <b>default</b> )	GNSS DOP and Active Satellites
GSV ( <b>default</b> )	GNSS Satellites in View
RMC ( <b>default</b> )	Recommended Minimum Specific GNSS data
VTG	Course Over Ground and Ground Speed
ZDA	Time and Date

The detail information please refers to RBXXXXXX series GPS module NMEA protocol reference manual.

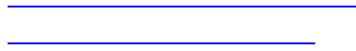

# Application Circuit

## Optional Accelerometer

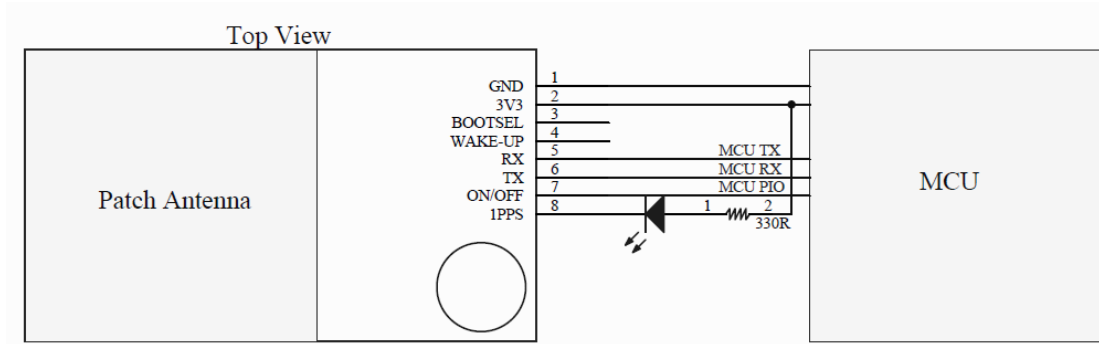

### Application for ON/OFF function

ON/OFF is Power control pin

The turn on command is a hardware feature of the Power Control FSM based on sensing a rising edge on the pin.

The turn off command is a software feature based on interrupts related to rising and/or falling edges and/or sensing of pin levels.

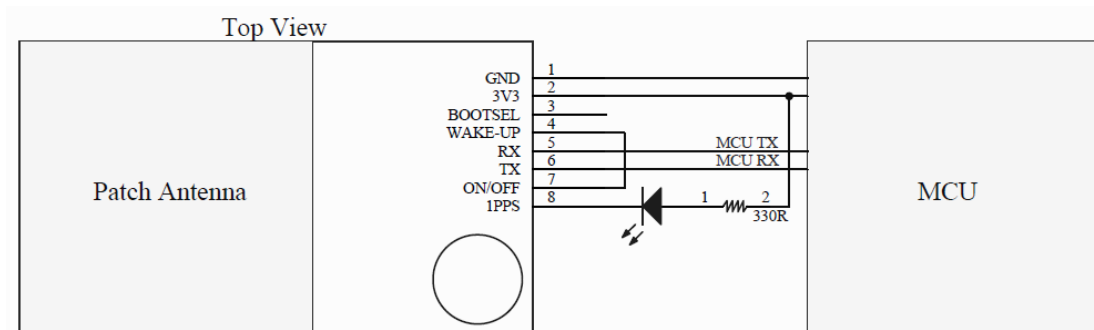

### Application for No-Use ON/OFF function