

RB-19LP
SiRF Star III
Low Power
GPS Module

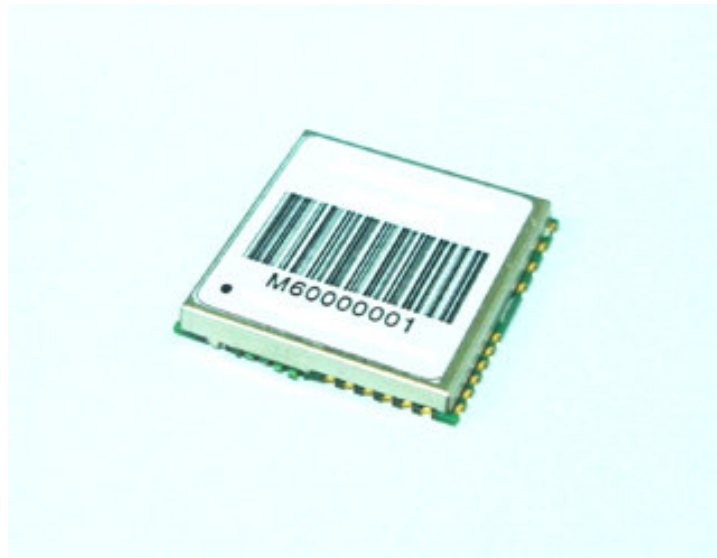

User's Manual Ver 1.05

1. Introduction

1.1. Overview

This GPS module **RB-19LP** is a high sensitivity, compact size, plug & play also the Low Power consumption GPS module board designed for a broad spectrum of OEM system applications. This product is based on the SiRF Star III technology and it will track up to 20 satellites at a time while providing fast time-to-first-fix. Its far reaching capability meets the sensitivity & accuracy requirements of car navigation as well as other location-based applications, such as AVL system. Handheld navigator, PDAs, Wrist Watches, Personal Locators, Toll collection, Fleet Management, pocket PC, or any battery operated navigation system.

The **RB-19LP** design utilizes the latest surface mount technology and high level circuit integration to achieve superior performance while minimizing dimension and power consumption. This hardware capability combined with software intelligence makes the board easy to be integrated and used in all kinds of navigation applications or products.

1.2. Main Feature

- Built-in high performance SiRF Star III Low power chipset.
- Current consumption 60mA
- 20 channels parallel.
- Average Cold Start in 42 seconds.
- -159 dBm sensitivity in tracking mode
- NMEA0183 compliant protocol
- Extreme fast TTFF at low signal level

2. Technical Specifications

2.1. Electrical Characteristics

General		Accuracy	
GPS Chip	SiRF Star III	Position	
Frequency	L1, 1575.42MHz	10 meters, 2D RMS 7 meters 2D RMS, WAAS corrected 1-5 meters, DGPS corrected	
C/A Code	1.023MHz chip rate	Velocity	0.1 m/sec
Channels	20 CH	Time	1ms synchronized to GPS time
		Datum	
		WGS-84	
Sensitivity		Dynamic Conditions	
To – 159Bm Tracking, Superior Urban Canyon Performance		Altitude	<18,000 m (60,000 feet)
Acquisition Rate		Velocity	<515 m/sec (1,000 knots)
Cold Start	42 sec, average	Acceleration	<4g
Warm Start	38 sec, average	Motional Jerk	<20 m/sec
Hot Start	1 sec, average	GPS Protocol	
Reacquisition	0.1sec, average	Default: NMEA-0183,	
Accuracy	Snap start 2 sec, average	GGA(1), GSA(1), GSV(1), RMC(1),	
Power		Band rate 9600 bps,	
Operation Power	3.3VDC+10%	Data bit : 8, stop bit : 1	
Current Consumption	60mA	Device Size	
Backup Power	3.3V	19.0 (L) x 19.0 (W) x 2.6 (H) mm	
Environmental			
Operating Temperature	- 40 °C ~ + 80 °C	Accessories	
Relative Humidity	5% to 95% non-condensing		

3. Applications

RB-19LP module board receiver is a high performance, ultra low power consumption, plug &play product. These applications are as follow.

- Car Navigation
- Wrist Watch
- Solar Operated Device
- Marine Navigation
- Fleet Management
- AVL and Location-Based Services
- Radar detector with GPS function
- Hand-Held Device for Personal Positioning and Navigation
- Ideal for PAD, Pocket PC and Other Computing Devices at GPS Application

4. Mechanical Dimensions

4.1 Dimension

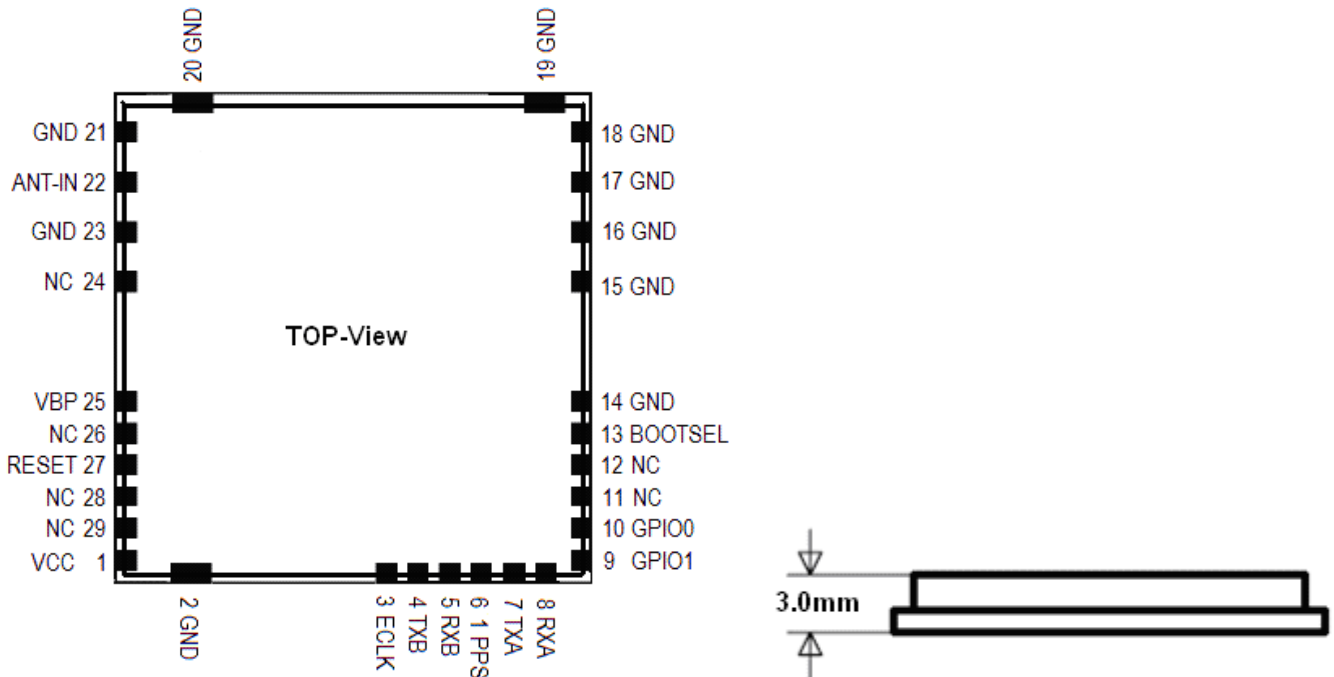

4.2 Recommend PCB Layout

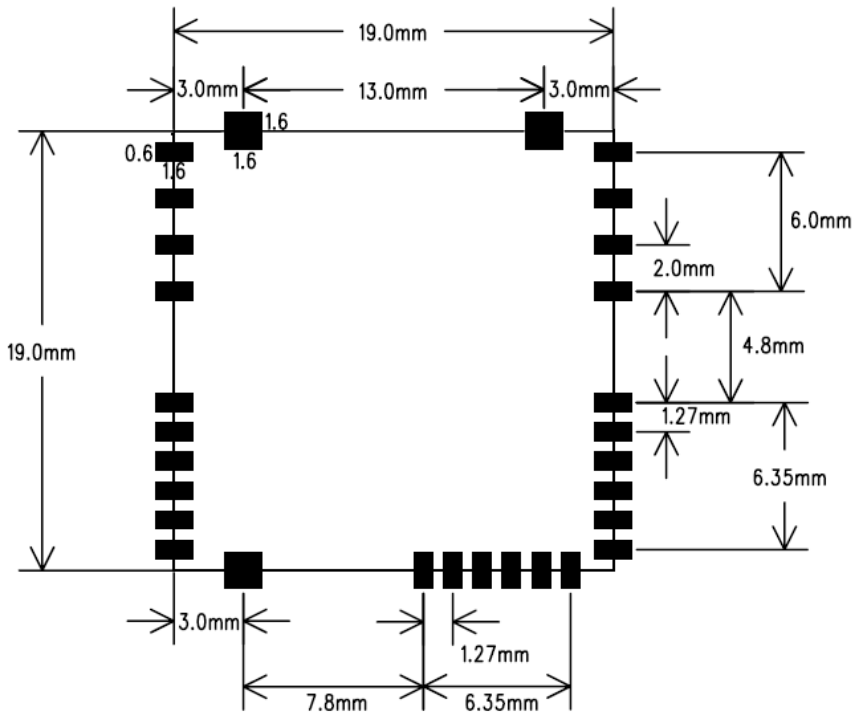

Board dimensions (in mm)

5. Board connections

PIN	Signal name	I/O	Description	Note
1	VCC	I	Supply Voltage (3.0V~3.6V)	
2	GND			
3	ECLK	I	External CMOS clock source	
4	TXB	O	Serial outputs for channel B	
5	RXB	I	Serial inputs for channel B	
6	1 PPS	I/O	One pulse per second	
7	TXA	O	Serial outputs for channel A	
8	RXA	I	Serial inputs for channel A	
9	GPIO1	I/O	GPS Status	GPS fixed: Clock("H" 500ms; "L" 500ms) GPS unfixed: "H"
10	GPIO0	I/O		Leave unconnected if not used
11	NC			
12	NC			
13	BOOTSEL	I	Module boots into special debug mode if VCC during reset	Leave unconnected if not used
14	GND			
15	GND			
16	GND			
17	GND			
18	GND			
19	GND			
20	GND			
21	GND			
22	ANT-IN	I	GPS signal from antenna (supply 2.85V out)	50Ω (1.57542 GHz)
23	GND			
24	NC			
25	VBP	I	Backup Voltage supply(2.85V)	Leave unconnected if not used
26	NC			
27	RESET	I/O	Active low reset	Leave unconnected if not used
28	NC			
29	NC			

RESET

An external reset is initiated by pulling RESET low for at least 1 μ s. If not used, RESET can be left unconnected since there is an internal 10k pull-up resistor. RESET is also used in Push-to-Fix mode in order to wake up the unit and request a position fix. Minimum pulse width is 1 μ s.

BOOTSEL

The boot signal BOOTSEL forces special debug mode when restarted with a reset signal or power-up. If not used, BOOTSEL can be left unconnected since there is an internal 100k pull-down resistor.

RF IN

The line on the PCB from the antenna (or antenna connector) has to be a controlled impedance line (Microstrip at 50 Ω).

VBAT

This is the battery backup supply that powers the SRAM and RTC when power is removed. Without an external backup battery or on board battery, engine board will execute a cold start after every turn on. To achieve the faster start-up offered by a hot or warm start, either a backup battery must be connected or battery installed on board.

TIMEMARK

This pin provides one pulse per second output from the engine board which is synchronized to within one microsecond of GPS time. The output is TTL negative level signal with negative logic.

6. Electrical Specification

Absolute Maximum Ratings

Parameter	Min	Max	Unit
Power supply voltage(VCC,VCC-RF)		3.6	V
Input/Output Pin voltage		5.25	V
RTC Voltage		2.0	V
Latch-up Current		±200	mA
Storage temperature	-65	150	°C

Warning – Stressing the device beyond the “Absolute Maximum Ratings” may cause permanent damage. These are stress ratings only. Operation beyond “Operating conditions” is not recommended and extended exposure beyond the “Operating condition” may affect device reliability. This module is not protected against over voltage, reversed voltage or short current of RF_IN port.

7. Operating Conditions

(Test Temperature: 25°C)

Parameter	Condition	Min	Typ	Max	Unit
Operating supply voltage	VCC	3.0	3.3	3.6	V
Operating supply ripple voltage				50	mV
Backup battery input voltage	V-BAT	1.9		3.0	V
I/O input low level				0.3x VCC	V
I/O input high level		0.7x VCC			V
I/O output high level	Loh=2mA	2.4	2.8		V
I/O output low level	Lol=2mA		0.2	0.4	V
Antenna input voltage	V_ANT	2.7	2.8	3.0	V
Sustained supply current	VCC=3.3V		40		mA
Peak supply current	VCC=3.3V		47		mA
Operating temperature	VCC=3.3V	-40	25	+85	°C

8. Application Schematic

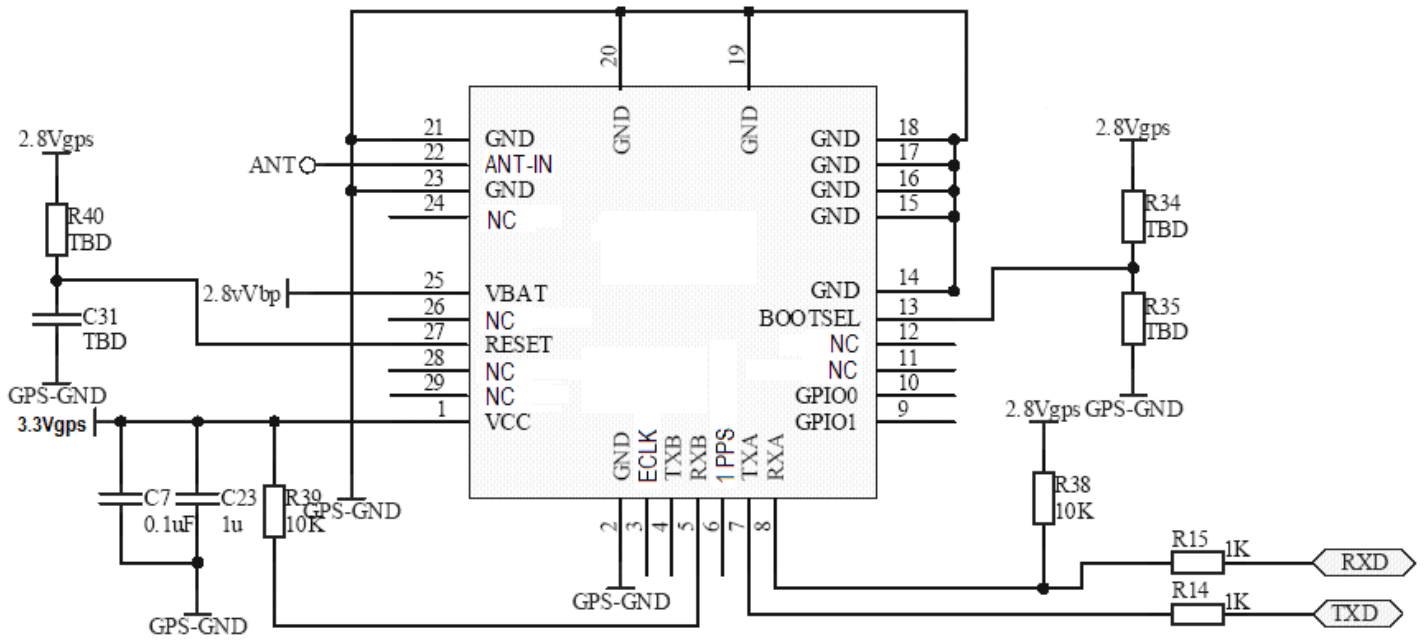

Appendix A: NMEA output message

NMEA record	Description
GGA	Global positioning system fixed data
GLL	Geographic position - latitude/longitude
GSA	GNSS DOP and active satellites
GSV	GNSS satellites in view
RMC	Recommended minimum specific GNSS data
VTG	Course over ground and ground speed

● GGA--- Global Positioning System Fixed Data

Table 5.1-2 contains the values for the following example:

```
$GPGGA,053740.000,2503.6319,N,12136.0099,E,1,08,1.1,63.8,M,15.2,M,,0000*64
```

Table 5.1- 2 GGA Data Format

Name	Example	Units	Description
Message ID	\$GPGGA		GGA protocol header
UTC Time	053740.000		hhmmss.sss
Latitude	2503.6319		ddmm.mmmm
N/S indicator	N		N=north or S=south
Longitude	12136.0099		dddmm.mmmm
E/W Indicator	E		E=east or W=west
Position Fix Indicator	1		See Table 5.1-3
Satellites Used	08		Range 0 to 12
HDOP	1.1		Horizontal Dilution of Precision
MSL Altitude	63.8	meters	
Units	M	meters	
Geoid Separation	15.2	meters	
Units	M	meters	
Age of Diff. Corr.		second	Null fields when DGPS is not used
Diff. Ref. Station ID	0000		
Checksum	*64		
<CR> <LF>			End of message termination

Table 5.1-3 Position Fix Indicators

Value	Description
0	Fix not available or invalid
1	GPS SPS Mode, fix valid
2	Differential GPS, SPS Mode, fix valid
3-5	Not supported
6	Dead Reckoning Mode, fix valid

● **GLL--- Geographic Position – Latitude/Longitude**

Table 5.1-4 contains the values for the following example:

\$GPGLL,2503.6319,N,12136.0099,E,053740.000,A,A*52

Table 5.1-4 GLL Data Format

Name	Example	Units	Description
Message ID	\$GPGLL		GLL protocol header
Latitude	2503.6319		ddmm.mmmm
N/S indicator	N		N=north or S=south
Longitude	12136.0099		dddmm.mmmm
E/W indicator	E		E=east or W=west
UTC Time	053740.000		hhmmss.sss
Status	A		A=data valid or V=data not valid
Mode	A		A=autonomous, D=DGPS, E=DR
Checksum	*52		
<CR> <LF>			End of message termination

● **GSA---GNSS DOP and Active Satellites**

Table 5.1-5 contains the values for the following example:

\$GPGSA,A,3,24,07,17,11,28,08,20,04,,,,,2.0,1.1,1.7*35

Table 5.1-5 GSA Data Format

Name	Example	Units	Description
Message ID	\$GPGSA		GSA protocol header
Mode 1	A		See Table 5.1-6
Mode 2	3		See Table 5.1-7
ID of satellite used	24		Sv on Channel 1
ID of satellite used	07		Sv on Channel 2
....		
ID of satellite used			Sv on Channel 12
PDOP	2.0		Position Dilution of Precision
HDOP	1.1		Horizontal Dilution of Precision
VDOP	1.7		Vertical Dilution of Precision
Checksum	*35		
<CR> <LF>			End of message termination

Table 5.1-6 Mode 1

Value	Description
M	Manual- forced to operate in 2D or 3D mode
A	Automatic-allowed to automatically switch 2D/3D

Table 5.1-7 Mode 2

Value	Description
1	Fix not available
2	2D
3	3D

● **GSV---GNSS Satellites in View**

Table 5.1-8 contains the values for the following example:

```
$GPGSV,3,1,12,28,81,285,42,24,67,302,46,31,54,354,,20,51,077,46*73
$GPGSV,3,2,12,17,41,328,45,07,32,315,45,04,31,250,40,11,25,046,41*75
$GPGSV,3,3,12,08,22,214,38,27,08,190,16,19,05,092,33,23,04,127,*7B
```

Table 5.1-8 GSV Data Format

Name	Example	Units	Description
Message ID	\$GPGSV		GSV protocol header
Total number of messages ¹	3		Range 1 to 3
Message number ¹	1		Range 1 to 3
Satellites in view	12		
Satellite ID	28		Channel 1 (Range 01 to 32)
Elevation	81	degrees	Channel 1 (Range 00 to 90)
Azimuth	285	degrees	Channel 1 (Range 000 to 359)
SNR (C/No)	42	dB-Hz	Channel 1 (Range 00 to 99, null when not tracking)
Satellite ID	20		Channel 4 (Range 01 to 32)
Elevation	51	degrees	Channel 4 (Range 00 to 90)
Azimuth	077	degrees	Channel 4 (Range 000 to 359)
SNR (C/No)	46	dB-Hz	Channel 4 (Range 00 to 99, null when not tracking)
Checksum	*73		
<CR> <LF>			End of message termination

1. Depending on the number of satellites tracked multiple messages of GSV data may be required.

● **RMC---Recommended Minimum Specific GNSS Data**

Table 5.1-9 contains the values for the following example:

\$GPRMC,053740.000,A,2503.6319,N,12136.0099,E,2.69,79.65,100106,,,A*53

Table 5.1-9 RMC Data Format

Name	Example	Units	Description
Message ID	\$GPRMC		RMC protocol header
UTC Time	053740.000		hhmmss.sss
Status	A		A=data valid or V=data not valid
Latitude	2503.6319		ddmm.mmmm
N/S Indicator	N		N=north or S=south
Longitude	12136.0099		dddmm.mmmm
E/W Indicator	E		E=east or W=west
Speed over ground	2.69	knots	True
Course over ground	79.65	degrees	
Date	100106		ddmmyy
Magnetic variation		degrees	
Variation sense			E=east or W=west (Not shown)
Mode	A		A=autonomous, D=DGPS, E=DR
Checksum	*53		
<CR> <LF>			End of message termination

● **VTG---Course Over Ground and Ground Speed**

Table 5.1-10 contains the values for the following example:

\$GPVTG,79.65,T,,M,2.69,N,5.0,K,A*38

Table 5.1-10 VTG Data Format

Name	Example	Units	Description
Message ID	\$GPVTG		VTG protocol header
Course over ground	79.65	degrees	Measured heading
Reference	T		True
Course over ground		degrees	Measured heading
Reference	M		Magnetic
Speed over ground	2.69	knots	Measured speed
Units	N		Knots
Speed over ground	5.0	km/hr	Measured speed
Units	K		Kilometer per hour
Mode	A		A=autonomous, D=DGPS, E=DR
Checksum	*38		
<CR> <LF>			End of message termination

Appendix B: Proprietary NMEA input message

Table 5.2-1 Message Parameters

Start Sequence	Payload	Checksum	End Sequence
\$PSRF<MID> ¹	Data ²	*CKSUM ³	<CR><LF> ⁴

1. Message Identifier consisting of three numeric characters. Input messages begin at MID 100.
2. Message specific data. Refer to a specific message section for <data>...<data> definition.
3. CKSUM is a two-hex character checksum as defined in the NMEA specification, *NMEA-0183Standard For Interfacing Marine Electronic Devices*. Use of checksums is required on all input messages.
4. Each message is terminated using Carriage Return (CR) Line Feed (LF) which is \r\n which is hex 0D0A. Because \r\n are not printable ASCII characters, they are omitted from the example strings, but must be sent to terminate the message and cause the receiver to process that input message.

Note: All fields in all proprietary NMEA messages are required, none are optional. All NMEA messages are comma delimited.

Table 5.2-2 Proprietary NMEA input messages

Message	MID ¹	Description
SetSerialPort	100	Set PORT A parameters and protocol
NavigationInitialization	101	Parameters required for start using X/Y/Z ²
SetDGPSPort	102	Set PORT B parameters for DGPS input
Query/Rate Control	103	Query standard NMEA message and/or set output rate
LLANavigationInitialization	104	Parameters required for start using Lat/Lon/Alt ³
Development Data On/Off	105	Development Data messages On/Off
Select Datum	106	Selection of datum to be used for coordinate transformations

1. Message Identification (MID).
2. Input coordinates must be WGS84.
3. Input coordinates must be WGS84

● 100---SetSerialPort

This command message is used to set the protocol (SiRF binary or NMEA) and/or the communication parameters (Baud, data bits, stop bits, and parity). Generally, this command is used to switch the module back to SiRF binary protocol mode where a more extensive command message set is available. When a valid message is received, the parameters are stored in battery-backed SRAM and the Evaluation Receiver restarts using the saved parameters.

Table 5.2-3 contains the input values for the following example:

Switch to SiRF binary protocol at 9600,8,N,1

```
$PSRF100,0,9600,8,1,0*0C
```

Table 5.2-3 Set Serial Port Data Format

Name	Example	Units	Description
Message ID	\$PSRF100		PSRF100 protocol header
Protocol	0		0=SiRF binary, 1=NMEA
Baud	9600		4800,9600,19200,38400,57600
DataBits	8		8,7 ¹
StopBits	1		0,1
Parity	0		0=None, 1=Odd, 2=Even
Checksum	*0C		
<CR><LF>			End of message termination

1. SiRF protocol is only valid for 8 data bits, 1 stop bit, and no parity.

● 101---NavigationInitialization

This command is used to initialize the Evaluation Receiver by providing current position (in X, Y, Z coordinates), clock offset, and time. This enables the Evaluation Receiver to search for the correct satellite signals at the correct signal

parameters. Correct initialization parameters enable the Evaluation Receiver to acquire signals quickly.

Table 5.2-4 contains the input values for the following example:

Start using known position and time

```
$PSRF101,-2686700,-4304200,3851624,96000,497260,921,12,3*1C
```

Table 5.2-4 Navigation Initialization Data Format

Name	Example	Units	Description
Message ID	\$PSRF101		PSRF101 protocol header
ECEF X	-2686700	meters	X coordinate position
ECEF Y	-4304200	meters	Y coordinate position
ECEF Z	3851624	meters	Z coordinate position
ClkOffset	96000	Hz	Clock Offset of the Evaluation Receiver ¹
TimeOfWeek	497260	seconds	GPS Time Of Week
WeekNo	921		GPS Week Number
ChannelCount	12		Range 1 to 12
ResetCfg	3		See Table 5.2-5
Checksum	*1C		
<CR><LF>			End of message termination

1. Use 0 for last saved value if available. If this is unavailable, a default value of 96000 is used.

Table 5.2-5 Reset Configuration

Hex	Description
0x01	Hot Start – All data valid
0x02	Warm Start – Ephemeris cleared
0x03	Warm Start (with Init) – Ephemeris cleared, initialization data loaded
0x04	Cold Start – Clears all data in memory
0x08	Clear Memory – Clears all data in memory and resets the receiver back to factory defaults

● 102---SetDGPSPort

This command is used to control the serial port used to receive RTCM differential corrections. Differential receivers may output corrections using different communication parameters. If a DGPS receiver is used that has different communication parameters, use this command to allow the receiver to correctly decode the data. When a valid message is received, the parameters are stored in battery-backed SRAM and the receiver restarts using the saved parameters.

Table 5.2-6 contains the input values for the following example:

Set DGPS Port to be 9600,8,N,1.

\$PSRF102,9600,8,1,0*12

Table 5.2-6 Set GPS Port Data Format

Name	Example	Units	Description
Message ID	\$PSRF102		PSRF102 protocol header
Baud	9600		4800,9600,19200,38400
DataBits	8		8,7
StopBits	1		0,1
Parity	0		0=None, 1=Odd, 2=Even
Checksum	*12		
<CR><LF>			End of message termination

Note: RTCM is not supported.

● 103---Query/Rate Control

This command is used to control the output of standard NMEA messages GGA, GLL, GSA, GSV, RMC, and VTG.

Using this command message, standard NMEA messages may be polled once, or setup for periodic output. Checksums may also be enabled or disabled depending on the needs of the receiving program. NMEA message settings are saved in battery-backed memory for each entry when the message is accepted.

Table 5.2-7 contains the input values for the following example:

1. Query the GGA message with checksum enabled

\$PSRF103,00,01,00,01*25

2. Enable VTG message for a 1 Hz constant output with checksum enabled

\$PSRF103,05,00,01,01*20

3. Disable VTG message

\$PSRF103,05,00,00,01*21

Table 5.2-7 Query/Rate Control Data Format (See example 1)

Name	Example	Units	Description
Message ID	\$PSRF103		PSRF103 protocol header
Msg	00		See Table 5.2-8
Mode	01		0=SetRate, 1=Query
Rate	00	seconds	Output – off=0, max=255
CksumEnable	01		0=Disable Checksum, 1=Enable Checksum
Checksum	*25		
<CR><LF>			End of message termination

Table 5.2-8 Messages

Value	Description
0	GGA
1	GLL
2	GSA
3	GSV
4	RMC
5	VTG
6	MSS (If internal beacon is supported)
7	Not defined
8	ZDA (if 1PPS output is supported)
9	Not defined

● **104---LLANavigationInitialization**

This command is used to initialize the Evaluation Receiver by providing current position (in latitude, longitude, and altitude coordinates), clock offset, and time. This enables the receiver to search for the correct satellite signals at the correct signal parameters. Correct initialization parameters enable the receiver to acquire signals quickly.

Table 5.2-9 contains the input values for the following example:

Start using known position and time.

\$PSRF104,37.3875111,-121.97232,0,96000,237759,1946,12,1*07

Table 5.2-9 LLA Navigation Initialization Data Format

Name	Example	Units	Description
Message ID	\$PSRF104		PSRF104 protocol header
Lat	37.3875111	degrees	Latitude position (Range 90 to -90)
Lon	-121.97232	degrees	Longitude position (Range 180 to -180)
Alt	0	meters	Altitude position
ClkOffset	96000	Hz	Clock Offset of the Evaluation Receiver ¹
TimeOfWeek	237759	seconds	GPS Time Of Week
WeekNo	1946		Extended GPS Week Number (1024 added)
ChannelCount	12		Range 1 to 12
ResetCfg	1		See Table 5.2-10
Checksum	*07		
<CR><LF>			End of message termination

1. Use 0 for last saved value if available. If this is unavailable, a default value of 96000 is used.

Table 5.2-10 Messages

Hex	Description
0x01	Hot Start – All data valid
0x02	Warm Start – Ephemeris cleared
0x03	Warm Start (with Init) – Ephemeris cleared, initialization data loaded
0x04	Cold Start – Clears all data in memory
0x08	Clear Memory – Clears all data in memory and resets receiver back to factory defaults

● 105---Development Data On/Off

Use this command to enable development data information if you are having trouble getting commands accepted. Invalid commands generate debug information that enables you to determine the source of the command rejection. Common reasons for input command rejection are invalid checksum or parameter out of specified range.

Table 5.2-11 contains the input values for the following example:

1. Debug On
\$PSRF105,1*3E
2. Debug Off
\$PSRF105,0*3F

Table 5.2-11 Development Data On/Off Data Format

Name	Example	Units	Description
Message ID	\$PSRF105		PSRF105 protocol header
Debug	1		0=Off, 1=On
Checksum	*3E		
<CR><LF>			End of message termination

● 106---Select Datum

\$PSGPS receivers perform initial position and velocity calculations using an earth-centered earth-fixed (ECEF) coordinate system. Results may be converted to an earth model (geoid) defined by the selected datum. The default datum is WGS 84 (World Geodetic System 1984) which provides a worldwide common grid system that may be translated into local coordinate systems or map datums. (Local map datums are a best fit to the local shape of the earth and not valid worldwide.)

Table 5.2-12 contains the input values for the following example:

- ```
Datum select TOKYO_MEAN
$PSRF106,178*32
```

Table 5.2-12 Development Data On/Off Data Format

| Name       | Example   | Units | Description                                                                           |
|------------|-----------|-------|---------------------------------------------------------------------------------------|
| Message ID | \$PSRF106 |       | PSRF106 protocol header                                                               |
| Datum      | 178       |       | 21=WGS84<br>178=TOKYO_MEAN<br>179=TOKYO_JAPAN<br>180=TOKYO_KOREA<br>181=TOKYO_OKINAWA |
| Checksum   | *32       |       |                                                                                       |
| <CR><LF>   |           |       | End of message termination                                                            |