

GSM Antenna

MODEL: TH-81ST

GSM850/PCS1900



1.. GENERAL DESCRIPTION

Model No	P/N
TH81ST	TH81ST-SMA(M)

Below is a table summarizing the antenna design specification.

1.1 Electrical Properties

Parameter	Description
Frequency Band	850/1900MHz (824~896 / 1850~1990 Mhz)
Nominal Impedance	50 ohm
Polarization	Vertical
Electrical Wave	1 /4 λ
Admitted Power radiation	1W
V.S.W.R	3.0:1
Antenna Average Gain	0 dBi
Note: Gain includes the cable loss	

1.2 Mechanical Properties

Parameter	Description
Antenna Type	External Antenna
Material	PVC
Touch Type	Screw Type

Connector Type	SMA 180° (Male)
Antenna Dimensions	38.2mm±2
Antenna Color	Black
Operating Temperature Range	-20°C~+60°C
Storage Temperature Range	-30°C~+70°C

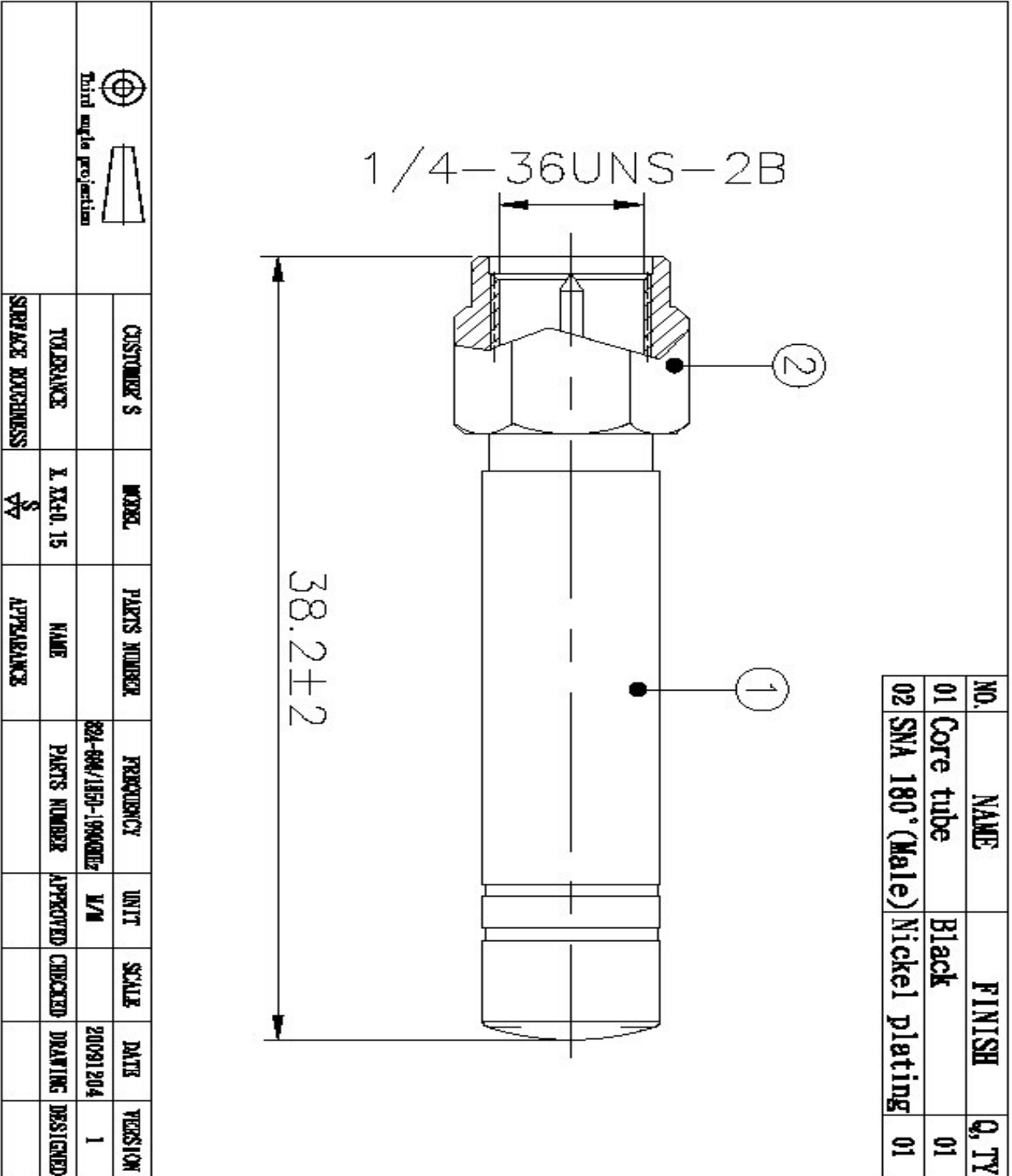

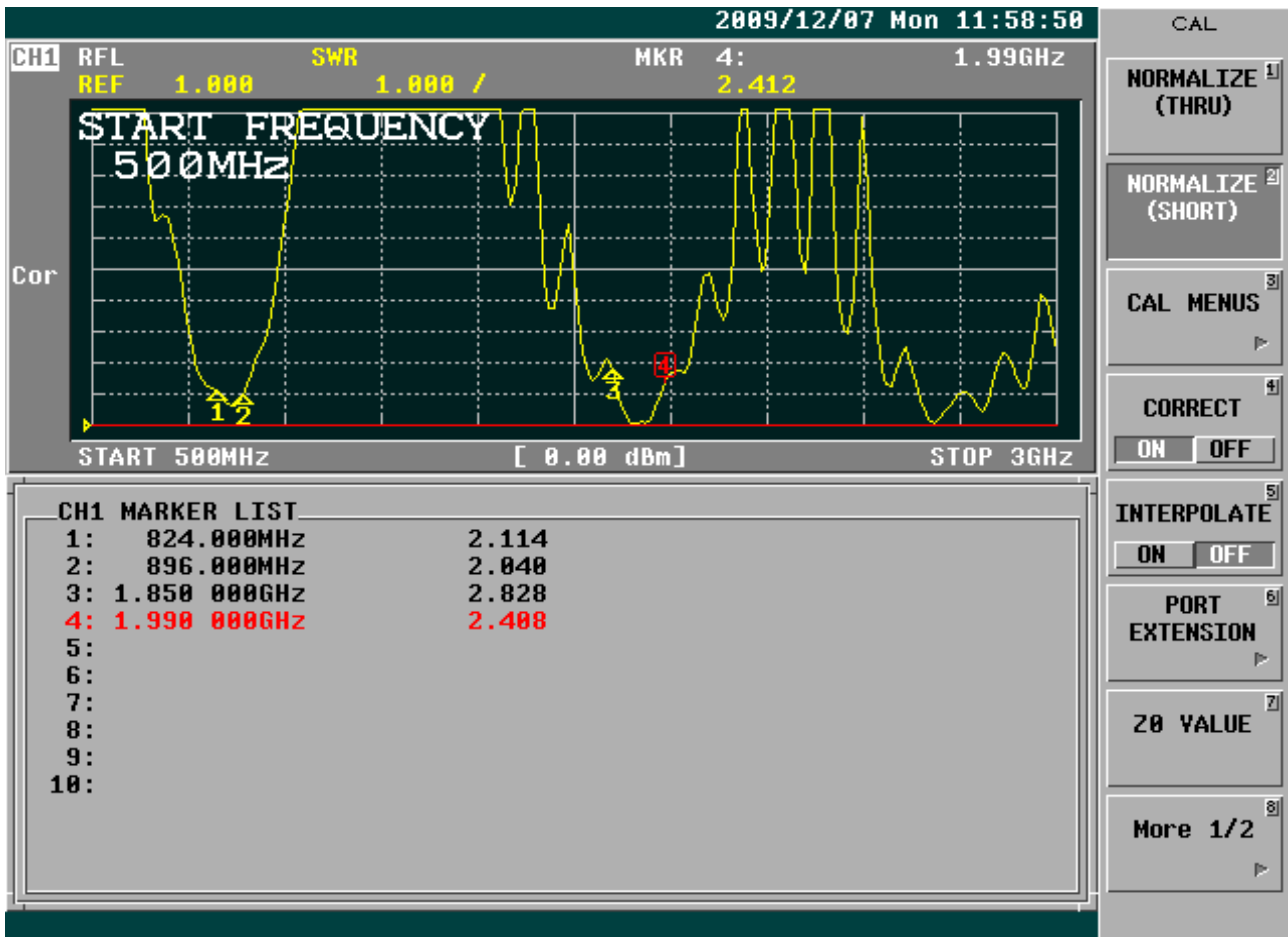
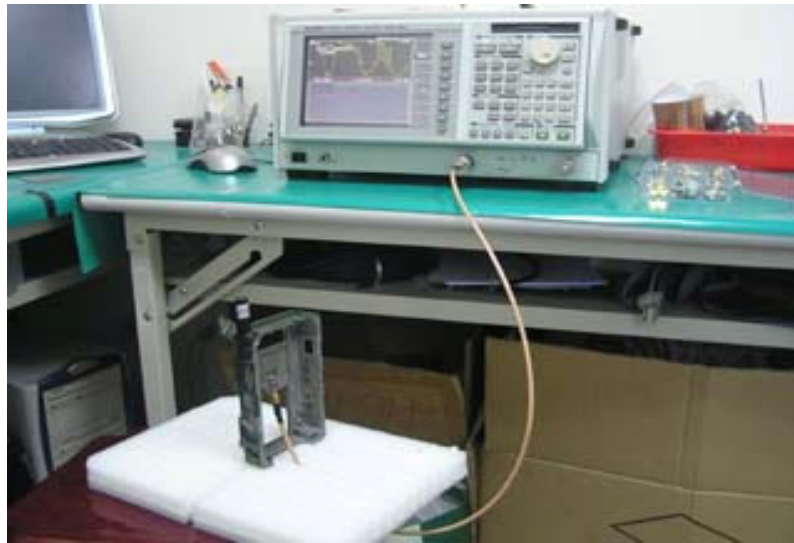

配件：SMA(J)+10.5CM+IPEX & 防水塞

