

Vehicle Locating & Marine Small GPS Antenna

MODEL: GA-62-TNC(F)

Small size and ruggedness, demand of vehicle locating and marine navigation GPS antenna that will sustain harsh environment.



- Low noise figure
- Fully weather proof.
- Ultra-high Sensitivity
- Compact construction
- Excellent temperature stability

The antenna system **GA-62** is the integration of the high performance GPS patch antenna and a low noise amplifier into state-of-the-art low a very low profile/extremely compact/fully waterproof antenna signal enclosure. When connected to a GPS receiver with +3~5V DC antenna power it provide excellent signal amplification and out-band-rejection for that receiver.

Features:

GPS antenna with double threaded bolts and through holes for cable routing with course & fine treaded pitch locking for wing-nut fastener and lock-nut to prevent vibrations and un-authorize removal.

Specifications:

PHYSICAL CONDITION	
Constructions:	Polycarbonate radome, detachable cable/connector for easy mount, rubber-O-ring between top radome and screw base for waterproof
Dimensions:	60mm(Dia.) x 18.5mm(H)
Weight:	65grams (w/o cable & connector).
Color:	Standard in ivory white, other colours available upon request.
Mounting:	Bulkhead mount with 0.8 inch threaded wing nut (standard accessory).
Cable & Connector	
RF cable:	TNC(M) +10 meter RG58 +BNC(M) (standard) other length (optional)
Pulling strength:	6 Kg @ 5sec. molded plastic on connector end for strain relief.
Connector	TNC(F)
Antenna Element	
Center Frequency:	1575.42 MHz +/-1.023 MHz
Polarization:	R.H.C.P. (Right Handed Circular Polarization).
Absolute Gain @ Zenith:	+5 dBi typical.

Gain @ 10° Elevation:	-1 dBi typical.
Axial Ratio:	3 dB max.
Output VSWR:	1.5 max
Output Impedance:	50 ohm
Low Noise Amplifier	
Center Frequency:	1575.42 MHz
Power Gain:	28db +/-4.5db
Bandwidth:	2 MHz min.
Noise Figure:	1.5 min.
Outer Band Attenuation:	20 dB min. @ Fo +/-50 Mhz.
Supply Voltages:	2.5~5.5V DC.
Current Consumption:	2.5V : 6.6mA Typ. 3V: 8.6mA Typ. 4V: 12.6mA Typ. 5V: 16.6mA Typ.
Output Impedance:	50W ohm
Overall Performance: (antenna element, LNA & coax cable)	
Center Frequency:	1575.42 Mhz.
Gain:	At 90° vertical to sky 30 ± 4.5dBi (cable loss) Note:1 Mounted on the 60mm x 60mm square ground plane
Noise Figure:	2.0 max.
Axial Ratio:	3 dB max.
Bandwidth:	2MHz min.
VSWR:	2.0 max.
Output Impedance:	50W ohm
Environmental	
Operating Temperature:	-40°C~ +85°C.
Storage Temperature:	-50°C~ +90°C.
Relative Humidity:	95% non-condensing.
Water Resistance:	100% waterproof.

* This specification is subject to change without prior notice

Data Updated: Jun.01, 2009



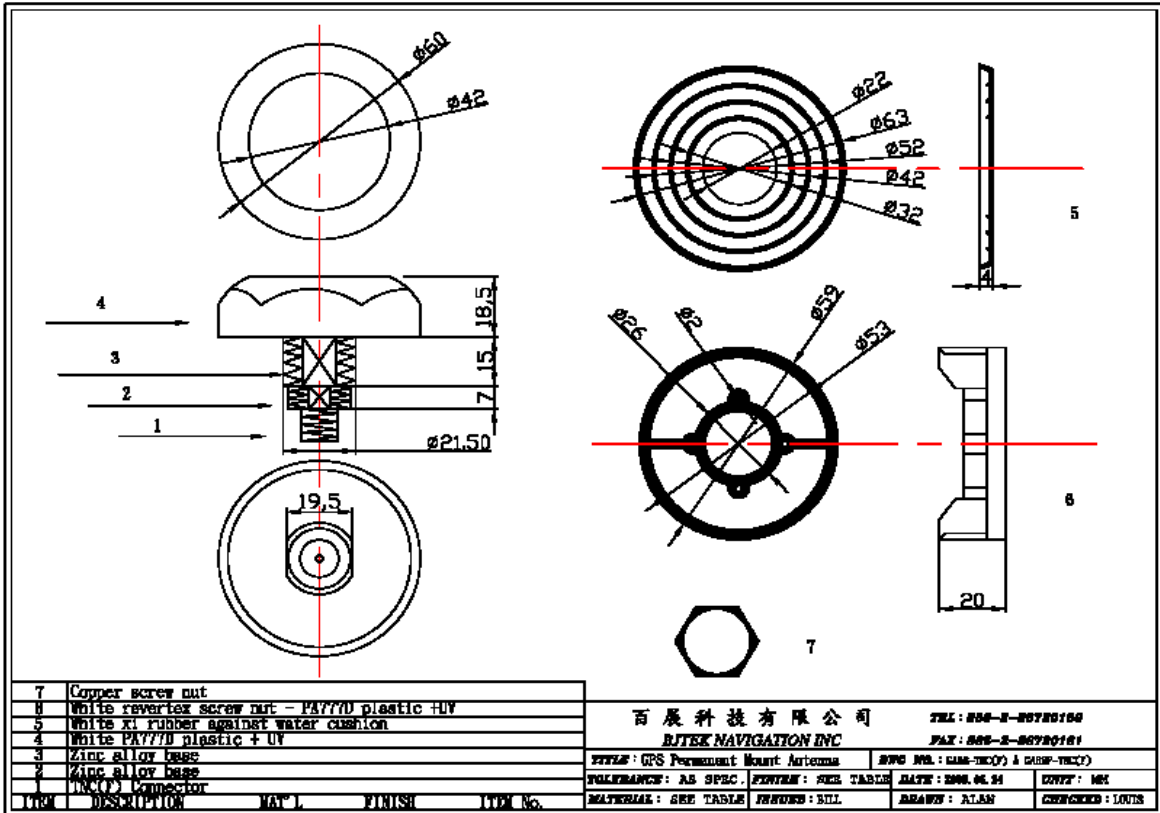

7	Copper screw nut			
6	White revertex screw nut - PA777D plastic HV			
5	White xi rubber against water cushion			
4	White PA777D plastic + UV			
3	Zinc alloy base			
2	Zinc alloy base			
1	INCO Connector			
ITEM	DESCRIPTION	MAT'L	FINISH	ITEM No.

百展科技有限公司		TEL: 886-2-88780100	
RJTEK NAVIGATION INC		FAX: 886-2-88780101	
TITLE: GPS Permanent Mount Antenna		SHEET NO.: 0406-TRC(1) & 0406-TRC(2)	
TOLERANCE: AS SPEC.	FORMAT: SEE TABLE	DATE: 2006.06.24	DIFF: MK
MATERIAL: SEE TABLE	REVISED: BILL	DRAWN: ALAN	CHECKED: LOUIS